

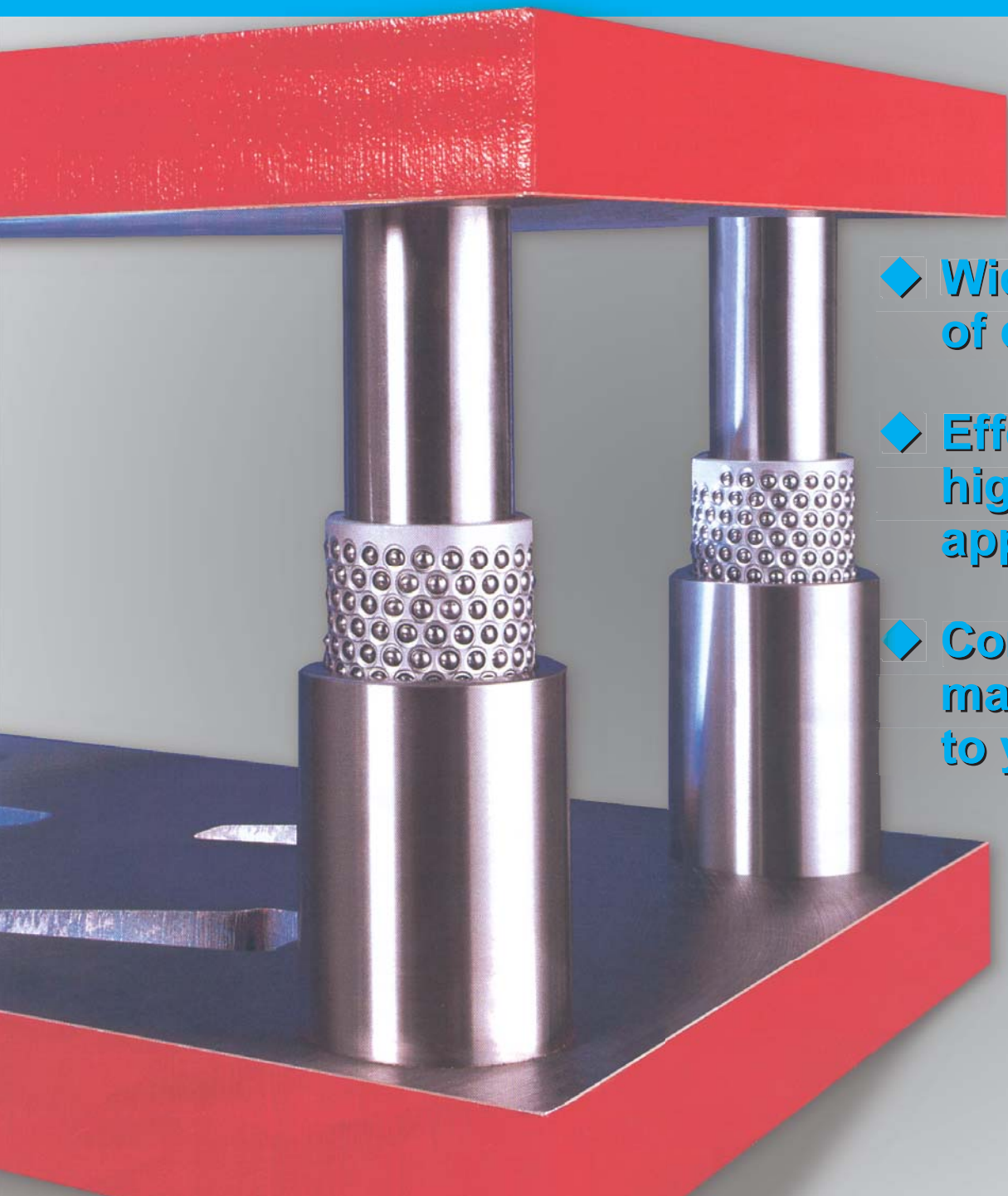

TRUSTED SOLUTIONS AND INNOVATION

BALL BEARING DIE SETS



- ◆ Wide selection of components
- ◆ Effective in high speed applications
- ◆ Complex machining to your print

BALL BEARING DIE SETS

Service We Deliver and Quality You Can Depend On

DANLY IEM is a leading manufacturer of die sets and die component products supplied globally to the parts forming industry. Backed by years of tool and die experience, quality and innovation are some of the reasons why our name is respected throughout the world. We have taken the lead role in creating and bringing new products to customers and helping them find solutions that improve their operations. Based on the capabilities **DANLY IEM** offers, we can help you to meet the demands of quick deliveries, technical support, quality products and competitive prices. **DANLY IEM** and its' broad distribution channels and direct sales personnel will assist you in any way to make your product a better and more profitable one.

We understand the demanding schedules of die builders and production personnel and have developed efficient manufacturing processes to shorten product lead times as well as put inventory on our shelves so you can have it in your facility when you need it. Put the **DANLY IEM** network to work for you. We've got the service you've been looking for.

Included in our full line offering are both inch and metric size die sets and die components that are designed to numerous die standards including ISO, NAAMS, JIS and many large automotive and appliance manufacturers' standards. The complete product offering includes:

- Ball bearing and friction style die sets including custom and catalog sets
- Machined plate
- Guide posts & bushings
- ISO and JIS Die springs
- In-die tapping units for both mechanical and hydraulic presses
- Formathane® Urethane springs, strippers, sheets, bars, rods and die cover film
- Diemakers' supplies such as pry bars, dowel pins, hoist rings, clamps and fasteners
- Standard and self-lubricating wear product including wear plate, wear strips, gibs, keeper plates and guide blocks
- Cam units, including Box and Bump styles
- Accu-Bend™ Rotary Benders
- Standard and Ball lock punches and retainers
- Air presses
- Pad retainers

Ball Bearing Die Sets

TABLE OF CONTENTS

PAGE NUMBER

General Information	1
Back Two Post All-Steel Ball Bearing Die Sets (AS-33-BB Series)	2
Center Two Post All-Steel Ball Bearing Die Sets (AS-34-BB Series)	3
Diagonal Two Post All-Steel Ball Bearing Die Sets (AS-35-BB Series)	4
Four Post All-Steel Ball Bearing Die Sets (AS-37-BB Series)	5
Ordering Information	6
Ball Bearing Components Technical Information	7
Aluminum Die Sets	8
Hoist Rings	9

Product Features

- ◆ Available with straight or demountable style guide posts.
- ◆ Available with straight sleeve or demountable bushings.
- ◆ Shanks furnished, if required, at additional cost.
- ◆ Meets ANSI B 5.25 Standards.
- ◆ Special machining to your print.
- ◆ 1" to 10" plate in stock for immediate delivery.



Ball Bearing Die Sets

With competitive pressures on the rise, the longer life and easier assembly of **DANLY IEM's** Ball Bearing Die Set – compared to plain bearing sets – just might be the edge you're looking for. Its fast assembly slashes costs in the building and maintaining of the die. And **DANLY IEM's** uncompromised material quality is legendary for long-lasting, profitable value.

Total Quality Management (TQM)

Materials for **DANLY IEM** Ball Bearing Bushing Die Sets and components are subjected 100% to inbound material inspections. Statistical process control (SPC) helps assure a high degree of precision throughout the manufacturing process. And, of course, the finished product is verified before shipment to our customers.

But, quality assurance requires even a greater commitment than just these benchmark tests. At **DANLY IEM**, Total Quality Management enlists every department, every workstation, every facet of the company's operation into a comprehensive quality effort.

From the sales and customer service representatives who assist you with your order, to the shipping department that expedites your delivery, quality at **DANLY IEM** is a team effort and it's everyone's top priority.

Back Two Post All-Steel Die Sets AS-33-BB Series

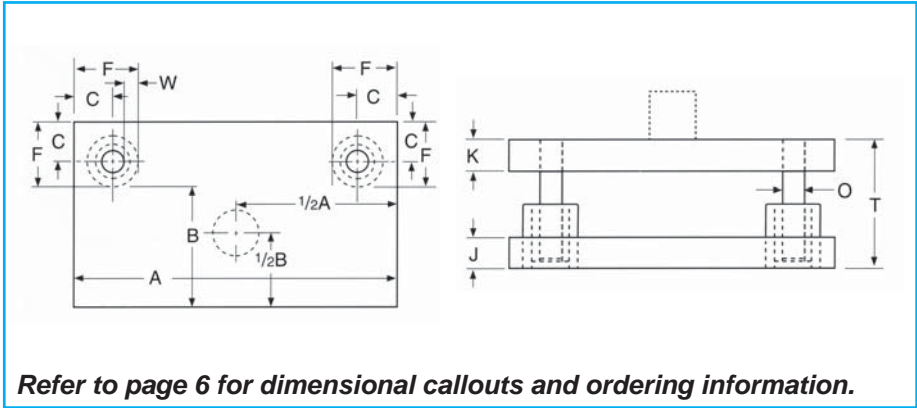
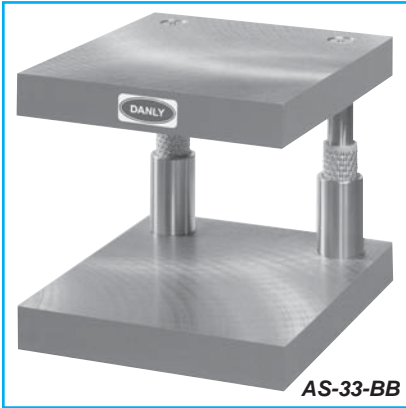

Suggested minimal dimensions are shown below:

MINIMUM THICKNESS RECOMMENDED	K	1¼	1¼	1½				1¾	2	2½	3																
	J	1¼	1½	1¾				2	2¼	2¾	3¼																
POST DIAMETER	O	1	1¼	1½				1¾	2	2½	3																
DIE SPACE A		8	10	12	14	16	18	20	22	24	26	28	30	32	34	36	40	45	50	55	60	65	70	80	90	100	
B	6																										
	8																										
	10																										
	12																										
	14																										
	16																										
	18																										
	20																										
	22																										
	24																										
	26																										
	28																										
	30																										
32																											
34																											
36																											
40																											

NOTE: Die space sizes are grouped within shaded areas which indicate suggested guide post diameters.

Diagonal Two Post All-Steel Die Sets

AS-35-BB Series



AS-35-BB

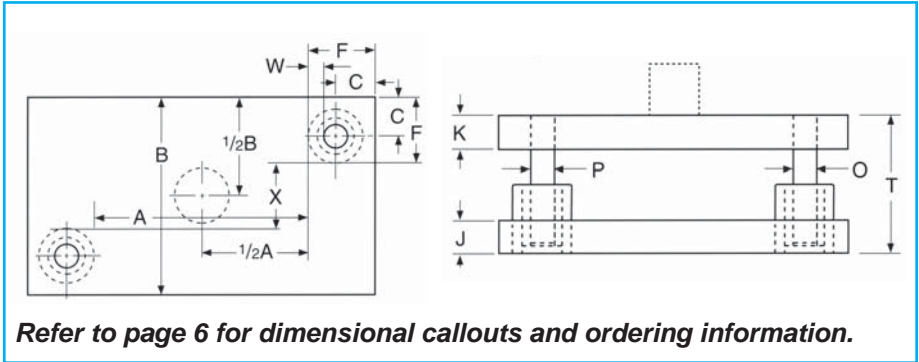

Refer to page 6 for dimensional callouts and ordering information.

Suggested minimal dimensions are shown below:

MINIMUM THICKNESS RECOMMENDED	K	1¼	1½	1¾	2	2½	3																			
	J	1½	1¾	2	2¼	2¾	3¼																			
POST DIAMETER	P	1	1¼	1½	1¾	2	2½																			
	O	1¼	1½	1¾	2	2½	3																			
DIE SPACE A →		6	8	10	12	14	16	18	20	22	24	26	28	30	32	34	36	40	45	50	55	60	65	70	80	
B ↓	6																									
	8																									
	10																									
	12																									
	14																									
	16																									
	18																									
	20																									
	22																									
	24																									
	26																									
	28																									
	30																									
32																										
34																										
36																										
40																										
45																										
50																										
55																										
60																										

NOTE: Die space sizes are grouped within shaded areas which indicate suggested guide post diameters.

Ordering Information

Nominal Guide Post Diameter (in)	C	Sleeve Bushing		Shoulder Bushing	
		F	W	F	W
1	1-3/4	2-11/16	7/16	2-7/8	9/16
1-1/4	1-7/8	2-15/16	7/16	3-1/16	9/16
1-1/2	2-1/8	3-3/8	1/2	3-9/16	11/16
1-3/4	2-1/4	3-5/8	1/2	3-13/16	11/16
2	2-1/2	4-1/8	5/8	4-5/16	13/16
2-1/2	2-7/8	4-3/4	5/8	5	13/16
3	3-1/4	5-3/8	5/8	5-5/8	7/8

NOTE: Diameter of larger post determines C and F dimensions for both posts.

Series	X	Y
AS-35BB	B minus 2F	–
AS-37BB	B minus 2F	A minus 2F

WHEN ORDERING, SPECIFY:

- Series number (i.e., AS-35BB).
- Dimensions A and B.
- Thickness of die holder J and punch holder K. (K thickness should be at least equal to guide post diameter O. For sleeve bushings, J thickness should be at least 1/4" larger than O.)
- Type of guide post – straight or demountable. Diameter of guide post O, if other than listed. (If larger or smaller guide post than listed is ordered, C and F dimensions will vary accordingly.)
- Type of bushing – demountable or straight sleeve.
- Demountable bushing clamp arrangement – state A, B or C (see page 7). If not specified, arrangement A will be furnished. Arrangement B is used for center post sets.
- Minimum shuheight by specifying T from bottom surface of die holder to top surface of punch holder.
- Stroke or ram movement of press.
- Operating condition (**Type I** – Preloaded, **Type II** – Relieving or **Type III** – Disengaging). Refer to our Pin & Bushing Catalog for detailed specifications.
- Size of shank, if required. These sets are regularly furnished without shanks. Inserted or welded steel shanks are available at additional cost.
 - ◆ 1-1/2" diameter x 2-1/8" long
 - ◆ 1-9/16" diameter x 2-1/8" long
 - ◆ 2" diameter x 2-7/8" long
 - ◆ 2-1/2" diameter x 2-7/8" long
 - ◆ 3" diameter x 2-7/8" long
- Clamping or lifting holes. Holes can be furnished to your specifications at additional costs.
- How shipment should be made.

Reverse Sets – Sets with B greater than A can be furnished if required for special feeding.

Special Machining – Sets can be provided with any special machining required. Send print.

Torch-Cut Holes – Holes of any shape can be torch-cut to your needs. Send template or print.

These die sets may not be returned for credit.

Ball Bearing Components Technical Information

DEMOUNTABLE SHOULDER BUSHING CLAMP ARRANGEMENT SELECTION DATA			
NOM. POST DIA.	A (L-R FEED)	B (F-B FEED) (CENTER POST SETS)	C (ROUND DIES)
1 & 1 1/4			
1 1/2 & 1 3/4			
2			
2 1/2 & 3			

NOTE: If not specified, clamp arrangement A will be furnished. Clamp arrangement B is furnished on Center Post Sets. AS-37BB sets with 1" and 1-1/4" diameter demountable bushings are furnished with four clamps on right front corner only.

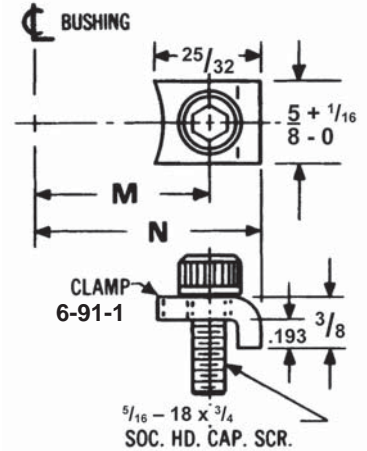

BUSHING CLAMP DATA

Nominal Post Diameter (in)	M	N	Per Bushing
1	1-5/16	1-11/16	3
1-1/4	1-7/16	1-13/16	
1-1/2	1-11/16	2-1/16	
1-3/4	1-13/16	2-3/16	4
2	2-1/16	2-7/16	
2-1/2	2-5/16	2-11/16	
3	2-5/8	3	

POST CLAMP DATA

Nominal Post Diameter (in)	M	N	Per Bushing
1	13/16	1-1/8	3
1-1/4	63/64	1-25/64	
1-1/2	1-1/8	1-17/32	
1-3/4	1-19/64	1-45/64	4
2	1-27/64	1-53/64	
2-1/2	1-43/64	2-5/64	
3	1-59/64	2-21/64	

BORING SPECIFICATIONS FOR BALL BEARING GUIDE POSTS AND BUSHINGS

Post Diameter A (in)	Bore Sizes (in)			
	Punch Holder for Posts		Die Shoe for Demountable Bushings	
	Minimum	Maximum	Minimum	Maximum
1	0.9980	0.9988	1.8748	1.8755
1-1/4	1.2480	1.2488	2.1248	2.1255
1-1/2	1.4975	1.4983	2.4998	2.5005
1-3/4	1.7475	1.7483	2.7498	2.7505
2	1.9975	1.9983	3.2498	3.2505
2-1/2	2.4970	2.4978	3.7498	3.7505
3	2.9970	2.9978	4.2498	4.2505

Aluminum Die Sets

AIRCRAFT QUALITY ALUMINUM, MADE IN THE U.S.A.

Any die set offered in steel can also be manufactured from aluminum. For some applications the advantages of light weight aluminum are worth looking into. For example, aluminum die sets weigh only about one third as much as their steel counterparts. That makes them much easier to handle, transport and store. Some feel that less weight in the die can reduce stress and wear on presses. Others report that the reduced weight of aluminum die sets can speed changeovers. For a variety of reasons, there is growing interest in aluminum.

MACHINED TO YOUR SPECIFICATIONS IN ANY SIZE OR STYLE

Aluminum is much easier to machine than steel and even intricate machining can be achieved without special tools. Aluminum die sets can be ground and EDM'd. Also drilled, planed, milled, reamed, and tapped. There's really no limitation to the machining which can be performed.

Today's aluminum is surprisingly strong, too. Tests show that aircraft aluminum outperforms 1020 hot rolled steel in both thermal conductivity and strength characteristics, as illustrated in the chart below.

VARIETY OF MATERIAL AND THICKNESSES AVAILABLE

Our die sets are usually made from QC-10™, but they are also available in 6061 or 7075 material in a variety of configurations. Plate thicknesses are available in 1, 1½, 2, 2½, 3, 3½, 3⅝, 4, 4⅝, 5, 5½, and 6 inches.

The combination of performance and value offered by steel is mighty tough to beat and there are certainly many applications where aluminum would not be the best choice. Because of the increased material expense, even with its easier machinability, aluminum die sets can be considerably more expensive than steel. And the greater malleability of aluminum could be a concern for some applications. Still, the overall benefits are worth looking into.

COMPARABLE TECHNICAL DATA

Properties	1020 H R Steel	4140 Alloy Steel	QC-10™ Aluminum	6061T651 Aluminum	7075T651 Aluminum
Tensile Strength	64	95	85	46	75
Yield Strength	50	60	77	40	65
Density	.283	.282	.103	.098	.101
Elasticity	30 x 10 ⁶	30 x 10 ⁶	10.4 x 10 ⁶	9.9 x 10 ⁶	10.3 x 10 ⁶
Brinnell	135	197	165–170	90–95	140–150
Coefficient of Expansion	6.3 x 10 ⁻⁶	6.21 x 10 ⁻⁶	13.7 x 10 ⁻⁶	13.1 x 10 ⁻⁶	13.1 x 10 ⁻⁶
Thermal Conductivity	20	24	92	95	75
Weldability	Good	Moderate	Moderate	Best	Better

Hoist Rings – Center Pull

Product Features

Center pull hoist rings are manufactured from 4140 and have a black oxide finish. The clevis bolt, pins, base, washer and bushing are magnetic particle inspected.

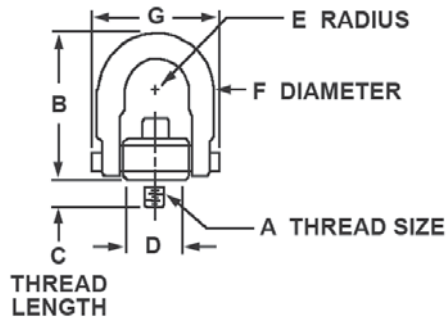

Thread Size A	Load Capacity* (lbs)	STANDARD CLEVIS		LONG CLEVIS		Thread Length C	D	Radius E	Diam. F	G	Torque ¹ (lb.ft.)
		Part Number	B	Part Number	B						
5/16 – 18	800	9-0109-88	2.67	–	–	9/16	.75	.43	.38	1.84	7
3/8 – 16	1000	9-0309-88	2.67	–	–	9/16	.75	.43	.38	1.84	12
1/2 – 13	2500	9-0417-88	3.75	–	–	1-1/16	1.20	.69	.50	2.56	28
		9-0412-88	4.78	9-0412-89	6.72	3/4	1.50	.88	.75	3.52	28
		9-0416-88	4.78	9-0416-89	6.72	1	1.50	.88	.75	3.52	28
		9-0420-88	4.78	9-0420-89	6.72	1-1/4	1.50	.88	.75	3.52	28
5/8 – 11	4000	9-0516-88	4.78	9-0516-89	6.72	1	1.50	.88	.75	3.52	60
		9-0520-88	4.78	9-0520-89	6.72	1-1/4	1.50	.88	.75	3.52	60
3/4 – 10	5000	9-0616-88	4.78	9-0616-89	6.72	1	1.50	.88	.75	3.52	100
		9-0624-88	4.78	9-0624-89	6.72	1-1/4	1.50	.88	.75	3.52	100
	7000	9-0616-881	6.52	9-0616-891	8.11	1	2.31	1.40	1.00	5.14	100
		9-0624-881	6.52	9-0624-891	8.11	1-1/2	2.31	1.40	1.00	5.14	100
7/8 – 9	8000	9-0716-88	6.52	9-0716-89	8.11	1	2.31	1.40	1.00	5.14	160
1 – 8	10000	9-0820-88	6.52	9-0820-89	8.11	1-1/4	2.31	1.40	1.00	5.14	230
		9-0824-88	6.52	9-0824-89	8.11	1-1/2	2.31	1.40	1.00	5.14	230
		9-0836-88	6.52	9-0836-89	8.11	2-1/4	2.31	1.40	1.00	5.14	230
1-1/4 – 7	15000	9-1030-88	8.73	–	–	1-7/8	3.19	1.75	1.25	6.50	470
1-1/2 – 6	24000	9-1244-88	12.47	–	–	2-3/4	4.19	2.25	1.75	8.55	800
2 – 4-1/2	30000	9-1650-88	12.47	–	–	3-1/8	4.19	2.25	1.75	8.55	800

¹ Stated load capacity based on specific thread torques as shown in chart. It is recommended that these torques be used when installing hoist rings.

* Rated at 5:1 strength factor.

Hoist Rings – Side Pull



9-010-87

Product Features

Side pull hoist rings are manufactured from alloy steel and have a black oxide finish. The clevis, ring, bushing and cap screw are magnetic particle inspected. The clevis is x-rayed.

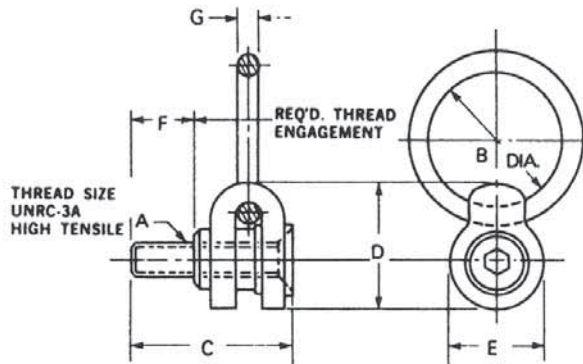

Part Number	Load Capacity*	A	B	C	D	E	F	G	Thread Torque ¹
9-01-87	650	5/16 – 18	2	2-1/8	2	1-1/2	5/8	3/8	3.5
9-03-87	800	3/8 – 16	2	2-3/8	2	1-1/2	3/4	3/8	4.5
9-04-87	1800	1/2 – 13	3	3-3/8	3-3/16	2-3/8	1	5/8	15.0
9-05-87	2500	5/8 – 11	3	3-5/8	3-3/16	2-3/8	1-1/4	5/8	25.0
9-06-87	4100	3/4 – 10	4	5	5	3-3/4	1-1/2	1	50.0
9-08-87	7100	1 – 8	4	5-3/8	5	3-3/4	2	1	90.0
9-10-87	14000	1-1/4 – 7	6	6-7/8	6-13/16	4-5/8	2	1-3/8	150.0
9-12-87	17200	1-1/2 – 6	6	7-7/8	6-13/16	4-5/8	2-1/2	1-3/8	250.0
9-16-87	29000	2 – 4-1/2	5-1/4 x 10-1/2	10	6-13/16	4-5/8	3-1/8	1-1/2	300.0

¹ Stated load capacity based on specific thread torques as shown in chart. It is recommended that these torques be used when installing hoist rings.

* Rated at 5:1 strength factor.

Notes

Notes

The DANLY IEM Value Proposition

- I. **DANLY IEM** is recognized as the leader in manufacturing quality die sets and related products to the global parts forming industry. Our reputation has been built by satisfying customer needs, and we are very strong in the automotive and appliance industries.
- II. **DANLY IEM** offers outstanding delivery on a consistent basis. Choosing us as a supplier means that our customers have a competitive advantage in delivering their products to the market.
- III. **DANLY IEM** has complex machining capabilities on die sets at several strategically located facilities. Locations throughout the USA means lower shipping costs and allowing **DANLY IEM** to machine complex die sets means the customer's machining centers have additional capacity.
- IV. **DANLY IEM's** vast breadth of products assures innovative solutions. We strive to address customer problems by utilizing our research and development department as well as other technical professionals.
- V. **DANLY IEM** has a technically trained sales force and distributor channels with engineering support. Sales, marketing and engineering professionals are available to support our product lines.

- **Competitive Prices**
- **Reliability and Performance**

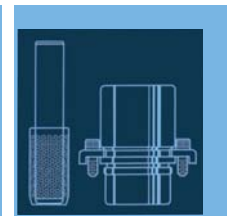
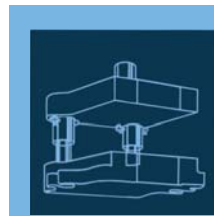

**...A LEADING MANUFACTURER
AND INNOVATOR OF DIE
SETS AND DIE COMPONENTS
SUPPLIED GLOBALLY TO THE
METAL FORMING INDUSTRY...**

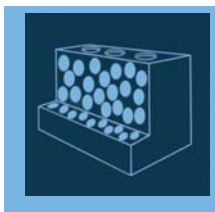
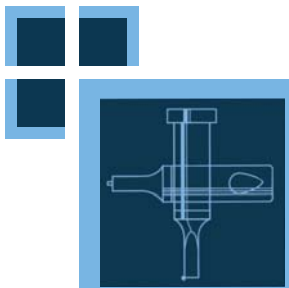

- **High Quality Design & Construction**
- **Outstanding Service & Support**



BALL BEARING DIE SETS



Distributed by:

www.danly.com
quotes@danly.com

WITHIN THE USA & CANADA

CALL: 800-243-2659

FAX: 800-833-2659

OUTSIDE THE USA & CANADA

CALL: 001-248-489-7816

FAX: 001-248-553-6842



The Anchor Danly Company