



TRUSTED SOLUTIONS AND INNOVATION

PINS & BUSHINGS – METRIC



CONTENTS

General Information	1
Plain & Ball Bearing Guide Posts	
Press Fit Guide Posts	2
Demountable Guide Posts	4
Automotive Straight Guide Posts	6
Plain Bearing & Self-Lubricating Bushings	
Automotive Demountable Self-Lubricating Guide Post Bushings	8
Automotive Demountable Self-Lubricating PAD Bushings	9
Automotive Demountable Self-Lubricating Bushings Clamps	10
Lifter Pins	13
Demountable Plain Bearing Bushings (Extra Long, Standard and Short Shoulder Series)	14
Demountable Plain Bearing Low Profile Bushings	16
Self-Lubricating Ejector Bushings	17
Ball Bearing Components	
Ball Bearing Cages	18
Ball Bearing Demountable Bushings	19
Ball Bearing Straight Sleeve Bushings	20
Demountable Ball Bearing Stripper Bushings & Cages	21
Technical Information	
Mounting Accessories	22
Ball Bearing Selection Guide	23
Bore Size Data	30
Clamping Specifications for Demountable Post & Bushings	32

General Information

As the premier die set manufacturer, we offer a complete line of catalog die sets as well as custom complex and simple sets. For replacement parts and for those customers wanting to assemble their own sets, an extensive line of catalog guide posts and bushings in both plain bearing and ball bearing styles is available for immediate delivery.

Our guide posts are available in press fit and demountable styles. Both the -82 and -83 posts can be used in a plain bearing or a ball bearing system. The NP line of guide posts fully meet NAAMS standards.

Our plain bearing bushings are available in press fit and demountable styles and are equipped with figure 8 oil grooves and lubrication fittings. They are available in three profiles: standard, short and extra long shoulder to give optimum flexibility in die set design. The bushings are also available in steel, bronze-plated and self-lubricating materials and are ideally suited for running with metric posts.

Demountable posts and bushings are tap fit into location and seat flush with the ground face of the punch holder or die shoe. They are held in place with toe clamps and screws which provide perfect alignment of the post and bushing with the bore perpendicular to the ground surface of the punch holder or shoe. The clamp and screws provide four times the holding power compared to pressed-in components, yet they can be easily removed and assembled thus simplifying die building and maintenance.

The ball bearing system includes press fit and demountable guide posts, press fit sleeves and demountable bushings as well as ball cages. The ball bearing guide posts are manufactured from hardened steel to assure free rolling of balls and high wear resistance. Each post is drilled and tapped at the bottom for mounting of the ball cage washer assembly. This unique mounting method permits the ball cage, except when under pre-load, to freely rotate 360° around the guide post thus eliminating scoring or tracking of the guide post surface. The ball bearings are arranged in the cage in a spiral pattern which also minimizes tracking or grooving and assures uniform wear.

Our demountable bushings and guide posts provide ease of assembly.



Demountable bushings are secured to the punch holder with clamps and screws, proving four times the holding power of pressed-in bushings.

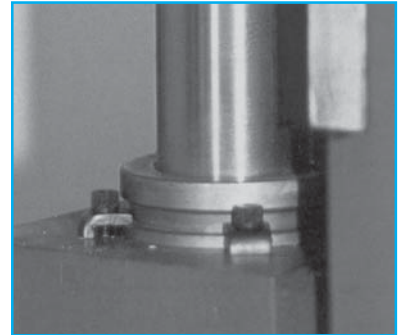

Specially-designed spiral patterns are drilled into our ball cages to control tracking and grooving.

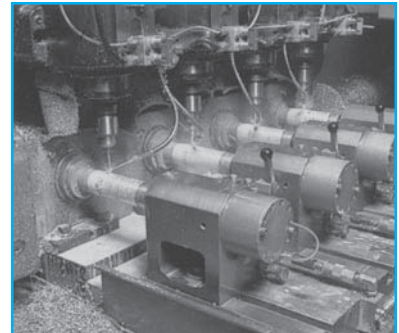

Special equipment spins ball bearings in place, then our ball cages move on to rigid quality inspection.

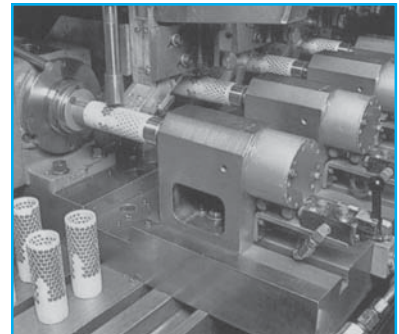

Plain & Ball Bearing Press Fit Guide Posts



Product Features

These press fit guide posts are designed to run in both a plain and ball bearing systems. They are manufactured from high quality hardened steel and finish ground for a high precision finish. The diameters that are used in ball bearing applications are drilled and tapped on the working end for the mounting of the ball cage washer assembly. This unique mounting method permits the ball cage, except when under preload, to freely rotate 360 degrees around the guide post, thus eliminating scoring or tracking of the guide post surface.

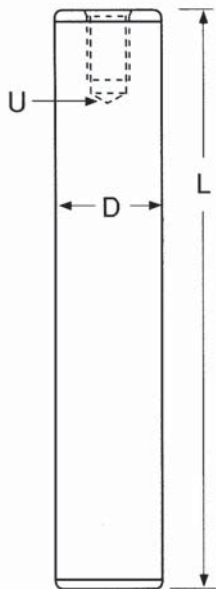

NOTES:

- ◆ Press fit length should be equal to or greater than the diameter of the guide post.
- ◆ See pages 30–31 for die set boring specifications.
- ◆ Ball Cage washer assembly sold separately and dependent on Type I, II or III assembly methods. Refer to page 22 for washer assembly part numbers.
- ◆ The diameters that are used in ball bearing applications are drilled and tapped on the working end for the mounting of the ball cage washer assembly.

D mm	L mm	U mm	Part Number
18	100	—	5-1810-82
	110		5-1811-82
	120		5-1812-82
	130		5-1813-82
	140		5-1814-82
	150		5-1815-82
	160		5-1816-82
	170		5-1817-82
	180		5-1818-82
	190		5-1819-82
19	200	—	5-1820-82
	100		5-1910-82
	110		5-1911-82
	120		5-1912-82
	130		5-1913-82
	140		5-1914-82
	150		5-1915-82
	160		5-1916-82
	170		5-1917-82
	180		5-1918-82
24	190	—	5-1919-82
	200		5-1920-82
	100		5-2410-82
	110		5-2411-82
	120		5-2412-82
	130		5-2413-82
	140		5-2414-82
	150		5-2415-82
	160		5-2416-82
	170		5-2417-82
	180		5-2418-82
	190		5-2419-82
	200		5-2420-82
	220		5-2422-82
240	5-2424-82		
260	5-2426-82		

Plain & Ball Bearing Press Fit Guide Posts

D mm	L mm	U mm	Part Number	D mm	L mm	U mm	Part Number	D mm	L mm	U mm	Part Number					
25	100	M6	5-2510-82	38	110	—	5-3811-82	48	280	—	5-4828-82					
	110		5-2511-82		120		5-3812-82		300		5-4830-82					
	120		5-2512-82		130		5-3813-82		320		5-4832-82					
	130		5-2513-82		140		5-3814-82		360		5-4836-82					
	140		5-2514-82		150		5-3815-82		400		5-4840-82					
	150		5-2515-82		160		5-3816-82		450		5-4845-82					
	160		5-2516-82		170		5-3817-82		50		130	M10	5-5013-82			
	170		5-2517-82		180		5-3818-82				140		5-5014-82			
	180		5-2518-82		190		5-3819-82				150		5-5015-82			
	190		5-2519-82		200		5-3820-82				160		5-5016-82			
	200		5-2520-82		220		5-3822-82				170		5-5017-82			
	220		5-2522-82		240		5-3824-82				180		5-5018-82			
	240		5-2524-82		260		5-3826-82				190		5-5019-82			
	260		5-2526-82		280		5-3828-82				200		5-5020-82			
30	100	—	5-3010-82	40	300	40	5-3830-82	63		220	M10		5-5022-82			
	110		5-3011-82		320		5-3832-82			240			5-5024-82			
	120		5-3012-82		360		5-3836-82			260			5-5026-82			
	130		5-3013-82		40		110			5-4011-82			280	5-5028-82		
	140		5-3014-82				120			5-4012-82			300	5-5030-82		
	150		5-3015-82				130			5-4013-82			320	5-5032-82		
	160		5-3016-82				140		5-4014-82	360		5-5036-82				
	170		5-3017-82				150		5-4015-82	400		5-5040-82				
	180		5-3018-82				160		5-4016-82	450		5-5045-82				
	190		5-3019-82				170		5-4017-82	80		200	M10	5-6320-82		
	200		5-3020-82				180		5-4018-82			220		5-6322-82		
	220		5-3022-82				190		5-4019-82			240		5-6324-82		
	240		5-3024-82				200		5-4020-82			260		5-6326-82		
	260		5-3026-82				220		5-4022-82			280		5-6328-82		
280	5-3028-82	240	5-4024-82	300		5-6330-82										
300	5-3030-82	260	5-4026-82	320		5-6332-82										
320	5-3032-82	280	5-4028-82	360		5-6336-82										
32	100	M6	5-3210-82	48	300	—	5-4030-82	80	400		M10	5-6340-82				
	110		5-3211-82		320		5-4032-82		450			5-6345-82				
	120		5-3212-82		360		5-4036-82		500			5-6350-82				
	130		5-3213-82		48		130		5-4813-82			80		200	M10	5-8020-82
	140		5-3214-82				140		5-4814-82					220		5-8022-82
	150		5-3215-82				150		5-4815-82					240		5-8024-82
	160		5-3216-82				160		5-4816-82	260			5-8026-82			
	170		5-3217-82				170		5-4817-82	280			5-8028-82			
	180		5-3218-82				180		5-4818-82	300			5-8030-82			
	190		5-3219-82				190		5-4819-82	320			5-8032-82			
	200		5-3220-82				200		5-4820-82	360			5-8036-82			
	220		5-3222-82				220		5-4822-82	400			5-8040-82			
	240		5-3224-82				240		5-4824-82	450			5-8045-82			
	260		5-3226-82				260		5-4826-82	500			5-8050-82			
280	5-3228-82															
300	5-3230-82															
320	5-3232-82															

Plain & Ball Bearing Demountable Guide Posts



Product Features

These demountable guide posts are designed to run in both plain and ball bearing systems. They are manufactured from high quality hardened steel and finish ground for a high precision finish. The diameters that are used in ball bearing applications are drilled and tapped on the working end for the mounting of the ball cage washer assembly. This unique mounting method permits the ball cage, except when under preload, to freely rotate 360 degrees around the guide post, thus eliminating scoring or tracking of the guide post surface.

There are two ways of mounting the demountable posts into the die set: they can be either held in place with toe clamps and screws or they can be mounted using a retainer plug. Either mounting option offers the benefit of easy removal, even multiple times without damaging or distorting the mounting holes in the die set, thus simplifying die building and maintenance. Demountable posts are also used to replace press fit posts when the press fit hole has been damaged and the straight pin no longer fits securely in the hole.

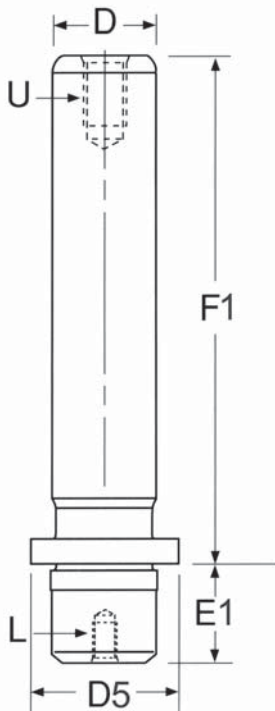

NOTES:

- ◆ All demountable guide posts are supplied with mounting clamps and screws. See pages 32–33 for clamping dimensions or to order additional toe clamps or mounting screws.
- ◆ Ball Cage washer assembly sold separately and dependent on Type 1, 2 or 3 assembly methods. Refer to page 22 for washer assembly part numbers.
- ◆ Retainer plugs must be ordered separately. Refer to page 32 for part numbers and dimensional information.
- ◆ The diameters that are used in ball bearing applications are drilled and tapped on the working end for the mounting of the ball cage washer assembly.

D mm	D5 mm	E1 mm	Tap Size L	Tap Size U
18	25.6	20	M5	—
19	25.6	20	M5	—
24	32.6	24	M6	—
25	32.6	24	M6	M6
30	40.6	30	M6	—
32	40.6	30	M6	M6
38	50.8	37	M10	—
40	50.8	37	M10	M10
48	63.8	45	M12	—
50	63.8	45	M12	M10
63	76	49	M16	M10
80	93	60	M16	M10

Plain & Ball Bearing Demountable Guide Posts

D mm	F1 mm	Part Number
18	80	5-1808-83
	90	5-1809-83
	100	5-1810-83
	110	5-1811-83
	120	5-1812-83
	140	5-1814-83
	160	5-1816-83
19	80	5-1908-83
	90	5-1909-83
	100	5-1910-83
	110	5-1911-83
	120	5-1912-83
	140	5-1914-83
24	80	5-2408-83
	90	5-2409-83
	100	5-2410-83
	110	5-2411-83
	120	5-2412-83
	130	5-2413-83
	140	5-2414-83
	150	5-2415-83
	160	5-2416-83
	170	5-2417-83
	180	5-2418-83
	190	5-2419-83
200	5-2420-83	
25	80	5-2508-83
	90	5-2509-83
	100	5-2510-83
	110	5-2511-83
	120	5-2512-83
	130	5-2513-83
	140	5-2514-83
	150	5-2515-83
	160	5-2516-83
	170	5-2517-83
	180	5-2518-83
	190	5-2519-83
200	5-2520-83	
30	100	5-3010-83
	110	5-3011-83
	120	5-3012-83
	130	5-3013-83
	140	5-3014-83
	150	5-3015-83
	160	5-3016-83
	170	5-3017-83
	180	5-3018-83
	190	5-3019-83

D mm	F1 mm	Part Number
30	200	5-3020-83
	220	5-3022-83
	240	5-3024-83
	280	5-3028-83
	100	5-3210-83
32	110	5-3211-83
	120	5-3212-83
	130	5-3213-83
	140	5-3214-83
	150	5-3215-83
	160	5-3216-83
	170	5-3217-83
	180	5-3218-83
	190	5-3219-83
	200	5-3220-83
	220	5-3222-83
	240	5-3224-83
38	280	5-3228-83
	110	5-3811-83
	120	5-3812-83
	130	5-3813-83
	140	5-3814-83
	150	5-3815-83
	160	5-3816-83
	170	5-3817-83
	180	5-3818-83
	190	5-3819-83
	200	5-3820-83
	220	5-3822-83
240	5-3824-83	
280	5-3828-83	
40	110	5-4011-83
	120	5-4012-83
	130	5-4013-83
	140	5-4014-83
	150	5-4015-83
	160	5-4016-83
	170	5-4017-83
	180	5-4018-83
	190	5-4019-83
	200	5-4020-83
	220	5-4022-83
	240	5-4024-83
280	5-4028-83	
48	110	5-4811-83
	120	5-4812-83
	130	5-4813-83
	140	5-4814-83
	150	5-4815-83
	160	5-4816-83
	160	5-4816-83

D mm	F1 mm	Part Number
48	170	5-4817-83
	180	5-4818-83
	190	5-4819-83
	200	5-4820-83
	220	5-4822-83
	240	5-4824-83
	280	5-4828-83
	320	5-4832-83
	360	5-4836-83
	400	5-4840-83
50	110	5-5011-83
	120	5-5012-83
	130	5-5013-83
	140	5-5014-83
	150	5-5015-83
	160	5-5016-83
	170	5-5017-83
	180	5-5018-83
	190	5-5019-83
	200	5-5020-83
	220	5-5022-83
	240	5-5024-83
	280	5-5028-83
	320	5-5032-83
360	5-5036-83	
400	5-5040-83	
63	120	5-6312-83
	140	5-6314-83
	160	5-6316-83
	180	5-6318-83
	200	5-6320-83
	220	5-6322-83
	240	5-6324-83
	280	5-6328-83
	320	5-6332-83
	360	5-6336-83
400	5-6340-83	
80	120	5-8012-83
	140	5-8014-83
	160	5-8016-83
	180	5-8018-83
	200	5-8020-83
	220	5-8022-83
	240	5-8024-83
	280	5-8028-83
	320	5-8032-83
	360	5-8036-83
400	5-8040-83	

Automotive Straight Guide Posts



Product Features

NAAMS guide posts are manufactured in accordance with the North American Automotive Metric Standards. They are manufactured from high quality hardened steel and finish ground for a high precision finish. Hardness is RC 57-62 with a minimum depth of 0.8 min. These posts are ideally suited for the self-lubricating NAAMS bushings.

To reduce tooling weight, the 100mm and 125mm diameter posts, NPH series, are manufactured with a through hole.

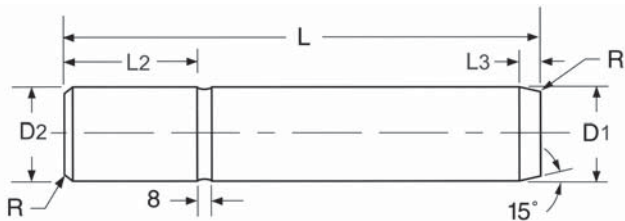

For NP Series (Solid Posts)

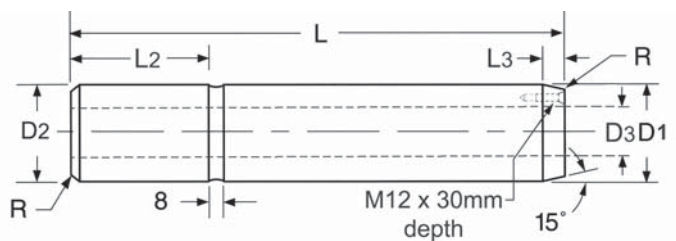

For NPH Series (Hollow Posts)

Part Number	NAAMS Code	GM Part Number	Chrysler Part Number	Ford Part Number	D1 & D2 mm	D2 Tol r6	D3 mm	L mm	L2 mm	L3 mm	R mm
NP25-80	G512508	—	19-245-6401	—	25	+.041 +.028	—	80	36	9	2
NP25-100	G512510	—	19-245-6402	—				100			
NP25-120	—	—	19-245-6403	—				120			
NP25-125	G512512	90.20.50-25125	19-245-6404	—				125			
NP25-140	G512514	90.20.50-25140	19-245-6405	WDX13-60-07025140				140			
NP25-160	G512516	90.20.50-25160	19-245-6406	WDX13-60-07025160				160			
NP25-180	G512518	90.20.50-25180	19-245-6407	WDX13-60-07025180				180			
NP32-100	G513210	—	19-245-6502	—	32	+.050 +.034	—	100	45	8	2
NP32-120	G513212	—	19-245-6503	—				120			
NP32-125	—	—	19-245-6504	—				125			
NP32-140	G513214	90.20.50-32140	19-245-6505	WDX13-60-07032140				140			
NP32-160	G513216	90.20.50-32160	19-245-6506	WDX13-60-07032160				160			
NP32-180	G513218	90.20.50-32180	19-245-6507	WDX13-60-07032180				180			
NP32-200	G513220	90.20.50-32200	19-245-6508	WDX13-60-07032200				200			
NP40-140	—	90.20.50-40140	—	—	40	+.050 +.034	—	140	56	8	2
NP40-160	G514016	90.20.50-40160	19-245-6606	WDX13-60-07040160				160			
NP40-180	G514018	90.20.50-40180	19-245-6607	WDX13-60-07040180				180			
NP40-200	G514020	90.20.50-40200	19-245-6608	WDX13-60-07040200				200			
NP40-225	G514022	90.20.50-40225	19-245-6609	WDX13-60-07040225				225			
NP40-250	G514025	90.20.50-40250	19-245-6610	WDX13-60-07040250				250			
NP40-280	—	90.20.50-40280	—	—				280			
NP50-160	G515016	90.20.50-50160	19-245-6806	WDX13-60-06050160	50	+.050 +.034	—	160	70	10	2.5
NP50-180	G515018	90.20.50-50180	19-245-6807	WDX13-60-06050180				180			
NP50-200	G515020	90.20.50-50200	19-245-6808	WDX13-60-06050200				200			
NP50-225	G515022	90.20.50-50225	19-245-6809	WDX13-60-06050225				225			
NP50-250	G515025	90.20.50-50250	19-245-6810	WDX13-60-06050250				250			
NP50-280	G515028	90.20.50-50280	19-245-6811	WDX13-60-06050280				280			
NP50-315	G515031	90.20.50-50315	19-245-6812	WDX13-60-06050315				315			
NP50-355	—	90.20.50-50355	—	—	355						

Automotive Straight Guide Posts

Part Number	NAAMS Code	GM Part Number	Chrysler Part Number	Ford Part Number	D1&D2 mm	D2 Tol r6	D3 mm	L mm	L2 mm	L3 mm	R mm
NP63-180	—	90.20.50-63180	—	—	63	+.060 +.041	—	180	80	10	2.5
NP63-200	G516320	90.20.50-63200	19-245-7008	WDX13-60-06063200				200			
NP63-225	G516322	90.20.50-63225	19-245-7009	WDX13-60-06063225				225			
NP63-250	G516325	90.20.50-63250	19-245-7010	WDX13-60-06063250				250			
NP63-280	G516328	90.20.50-63280	19-245-7011	WDX13-60-06063280				280			
NP63-315	G516331	90.20.50-63315	19-245-7012	WDX13-60-06063315				315			
NP63-355	G516335	90.20.50-63355	19-245-7014	WDX13-60-06063355				355			
NP63-400	G516340	90.20.50-63400	19-245-7016	WDX13-60-06063400				400			
NP63-450	—	90.20.50-63450	—	—				450			
NP63-500	G516350	90.20.50-63500	19-245-7020	—				500			
NP80-225	—	90.20.50-80225	19-245-7209	—	80	+.062 +.043	—	225	100	10	3
NP80-250	G518025	90.20.50-80250	19-245-7210	WDX13-60-06080250				250			
NP80-280	G518028	90.20.50-80280	19-245-7211	WDX13-60-06080280				280			
NP80-315	G518031	90.20.50-80315	19-245-7212	WDX13-60-06080315				315			
NP80-355	G518035	90.20.50-80355	19-245-7214	WDX13-60-06080355				355			
NP80-400	G518040	90.20.50-80400	19-245-7216	WDX13-60-06080400				400			
NP80-450	—	90.20.50-80450	—	WDX13-60-07080450				450			
NP80-500	G518050	90.20.50-80500	19-245-7220	WDX13-60-07080500				500			
NP100-250	—	90.20.50-100250	—	—	100	+.073 +.051	—	250	125	10	3
NP100-280	—	90.20.50-100280	—	—				280			
NP100-315	G511031	—	19-245-7412	WDX13-60-06100315				315			
NP100-355	G511035	—	19-245-7414	WDX13-60-06100355				355			
NP100-400	G511040	—	19-245-7416	WDX13-60-06100400				400			
NP100-450	—	90.20.50-100450	—	—				450			
NP100-500	G511050	90.20.50-100500	19-245-7420	WDX13-60-07100500				500			
NP100-550	—	90.20.50-100550	—	WDX13-60-07100550				550			
NP100-600	—	90.20.50-100600	—	WDX13-60-07100600				600			
NP100-650	—	90.20.50-100650	—	—				650			
NPH100315	—	90.20.50-100315	—	—	100	+.073 +.051	—	315	125	10	3
NPH100355	—	90.20.50-100355	—	—				355			
NPH100400	—	90.20.50-100400	—	—				400			
NPH100450	—	90.20.50-100450*	—	—				450			
NPH100500	—	90.20.50-100500	—	—				500			
NPH100550	—	90.20.50-100550*	—	—				550			
NPH100600	—	90.20.50-100600*	—	—				600			
NP115400	G511140	90.20.50-115400	19-245-7616	—	115	+.076 +.054	—	400	140	10	3
NP115500	G511150	90.20.50-115500	19-245-7620	—	500						
NP125-315	—	90.20.50-125315	—	—	125	+.088 +.063	—	315	140	12	3
NP125-355	—	90.20.50-125355	—	—				355			
NP125-400	G511240	90.20.50-125400	—	—				400			
NP125-450	G511245	90.20.50-125450	—	—				450			
NP125-500	G511250	90.20.50-125500	—	—				500			
NP125-550	G511255	90.20.50-125550	—	—				550			
NP125-600	G511260	90.20.50-125600	—	—				600			
NP125-650	G511265	90.20.50-125650	—	—				650			
NP125-700	G511270	90.20.50-125700	—	—				700			
NPH125315	—	90.20.50-125315	—	—	125	+.088 +.063	—	315	140	12	3
NPH125355	—	90.20.50-125355*	—	WDX13-60-05125355**				355			
NPH125400	—	90.20.50-125400	—	WDX13-60-05125400**				400			
NPH125450	—	90.20.50-125450	—	WDX13-60-05125450**				450			
NPH125500	—	90.20.50-125500	—	WDX13-60-05125500**				500			
NPH125550	—	90.20.50-125550	—	WDX13-60-05125550**				550			
NPH125600	—	90.20.50-125600	—	WDX13-60-05125600**				600			
NPH125650	—	90.20.50-125650	—	WDX13-60-05125650**				650			

* Not for North American Operations use.

** Non-standard parts. Parts must be ordered as shown.

Automotive Demountable Self-Lubricating Guide Post Bushings



Product Features

Demountable NAAMS bushings are self-lubricating and are available in guide post and pad styles. These bushings fully conform to the NAAMS, GM, Chrysler and Ford standards.

Self-lubricating bushings contain graphite plugs which are impregnated with oil. When the bushings reach 80-90°F as a result of friction between the bushing and guide post, oil is drawn from the plug, thus lubricating the wear surface. A dark smear pattern is created on the wear surface as the oil and graphite are imbedded into the bronze or steel grain. This provides the lubrication necessary for continuous performance of the tool.

Demountable bushings are tap fit into location and seat flush with the ground face of the punch holder. The bushings are held in place with toe clamps and screws which provide perfect alignment of the bushing with the bore perpendicular to the ground surface of the punch holder. Multiple standard clamps are available.

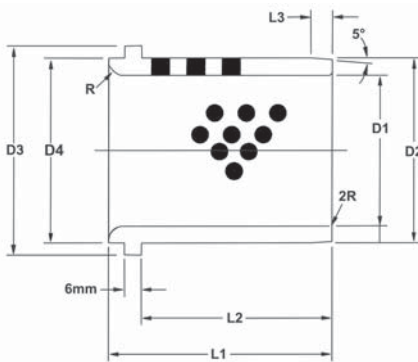

D1 mm	D2 mm	D3 mm	D4 mm	L1 mm	L2 mm	L3 mm	R mm	Part Numbers	NAAMS Bushing Number	GM Part Number	Chrysler Part Number	Ford Part Number
25	32	40	32	40	30	4	3	NM25	G612540	90.20.55-25	19-029-1010	WDX13-60-08025
32	40	50	40	50	40	4	3	NM32	G613250	90.20.55-32	19-029-1011	WDX13-60-08032
40	50	63	50	63	50	4	3	NM40	G614063	90.20.55-40	19-029-1012	WDX13-60-08040
50	63	71	63	71	56	5	5	NM50	G615071	90.20.55-50	19-029-1013	WDX13-60-08050
63	80	90	80	80	63	6	6	NM63	G616380	90.20.55-63	19-029-1014	WDX13-60-08063
80	100	112	100	100	80	8	8	NM80	G618010	90.20.55-80	19-029-1015	WDX13-60-08080
100	125	140	125	125	106	10	10	NM100	G611012	90.20.55-100	19-029-1016	WDX13-60-08100
100	125	140	125	77	58	12	12	NM100S	—	90.20.55-100S	—	—
115	140	155	140	140	120	12	10	NM115	G611114	—	19-029-1017	—
125	160	180	160	160	132	12	12	NM125	G611216	90.20.55-125	19-029-1018	WDX13-60-08125

CLAMP NOTES:

- See pages 10–12 for clamp part numbers and dimensional information.
- OUR** bushings will be supplied with (3) M8 toe clamps and screws (#6-99-1).
- NAAMS** bushings will be supplied with (3) M8 toe clamps and screws (#6-99-1).
- GM** bushings are supplied with NO clamps and screws. Order separately: for 25-50mm, order (1) 90.20.60A clamp per bushing; for 63-125mm, order (2) 90.20.60B clamps per bushing.
- CHRYSLER** guide post bushings are supplied with NO clamps or screws. Order STOP/BUSHING CLAMP COMBINATION BLOCK separately. See Table 1 for sizes and part numbers.
- Ford** bushings: 32-50mm are supplied with (1) toe clamp (#MMC0219); 63mm-100mm are supplied with (2) toe clamps (#MMC0219).

TABLE 1
STOP BLOCK/BUSHING CLAMPS

Chrysler Part Number	Bushing ID mm
19-010-1105	50mm
19-010-1106	63mm
19-010-1108	80mm
19-010-1110	100mm

Automotive Demountable Self-Lubricating PAD Bushings

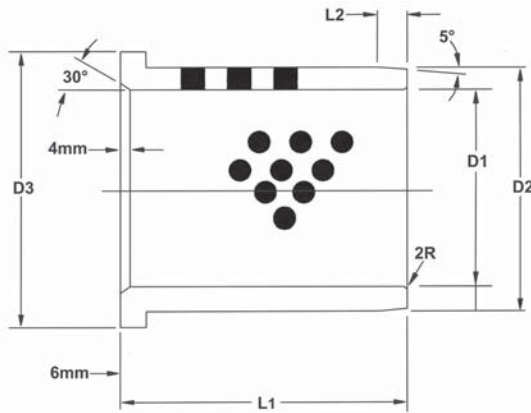

D1 mm	D2 mm	D3 mm	L1 mm	L2 mm	Part Numbers	NAAMS Code Number	GM Part Number	Chrysler Part Number	Ford Part Number
25	32	40	40	4	NM25PAD	G712540	90.30.10-25	19-029-0102	WDX13-80-09025
32	40	50	50	4	NM32PAD	G713250	90.30.10-32	19-029-0103	WDX13-80-09032
40	50	63	55	5	NM40PAD	G714055	90.30.10-40	19-029-0104	WDX13-80-09040
50	63	71	63	6	NM50PAD	G715063	90.30.10-50	19-029-0105*	WDX13-80-09050
63	80	90	75	8	NM63PAD	G716375	90.30.10-63	19-029-0106*	WDX13-80-09063
63	80	90	125	8	NM63-125PAD	—	—	19-028-0107*	—
80	100	112	90	10	NM80PAD	G718090	90.30.10-80	19-029-0108*	WDX13-80-09080
80	100	112	140	10	NM80-140PAD	—	—	19-029-0109*	—
100	125	140	115	12	NM100PAD	G711011	90.30.10-100	19-029-0110	WDX13-80-09100
100	125	140	165	12	NM100-165PAD	—	—	19-029-0111	—
125	160	180	138	12	NM125PAD	G711213	90.30.10-125	19-029-0112	—

CLAMP NOTES:

- See pages 10–12 for clamp part numbers and dimensional information.
- OUR** PAD bushings will be supplied with (3) M8 toe clamps and screws (#6-99-1).
- NAAMS** PAD bushings will be supplied with (3) M8 toe clamps and screws (#6-99-1).
- GM** PAD bushings are supplied with NO clamps and screws. Order separately; for 25-50mm, order (1) 90.20.60A clamp per bushing; for 63-125mm, order (2) 90.20.60B clamps per bushing.
- CHRYSLER** PAD bushings are supplied with (3) M10 toe clamps and screws (6-990-1). Chrysler PAD bushings with "*" DO NOT come with M10 clamps and screws (10/15/07 Die Standards). They use the PAD Bushing Retainer Block shown in Table 2 and must be ordered separately.
- Ford** PAD bushings: 32-50mm are supplied with (1) toe clamp (#MMC0219); 63mm-100mm are supplied with (2) toe clamps (#MMC0219).

TABLE 2
PAD BUSHING RETAINER
BLOCK CLAMPS

Chrysler Part Number	Pad Bushing ID mm
19-010-1185	50mm
19-010-1195 ¹	50mm
19-010-1186	63mm
19-010-1196 ¹	63mm
19-010-1188	80mm
19-010-1198 ¹	80mm

¹For bottoming of pads/lower rings.

Automotive Demountable Self-Lubricating Bushing Clamps

CLAMP SPECIFICATIONS – DANLY / IEM / NAAMS / CHRYSLER

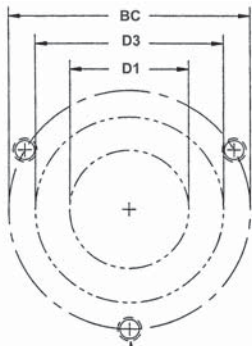

"D" TAP HOLES (3)
EQUALLY SPACED

NOTE: D1 = ID of bushing
D3 = OD of bushing shoulder

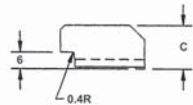
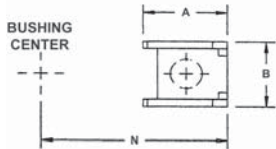

Part Number	NAAMS Number	Chrysler Number	A mm	B mm	C mm	D mm
6-99-1	G720000C	N/A	24.6	18.9	13	M8 x 1.25
6-990-1	G730000C	19-010-0101	27.9	23.5	15.5	M10 x 1.5

PART #6-99-1 (NAAMS #G720000C)

D1 mm	D3 mm	BC mm	N mm
32	50	68	45.1
40	63	81	51.6
50	71	89	55.6
63	90	108	65.1
80	112	130	76.1
100	140	158	90.1
115	155	173	97.6

PART #6-990-1 (NAAMS #G730000C)

D1 mm	D3 mm	BC mm	N mm
32	50	71	48.4
40	63	84	54.9
50	71	92	58.9
63	90	111	68.4
80	112	133	79.4
100	140	161	93.4
115	155	176	100.9
125	180	201	113.4

CLAMP SPECIFICATIONS – GM

GM Number	Bushing I.D.	C mm	D mm	E mm	F mm	G mm	H mm	J mm	K mm	Clamps Required
90.20.60A	25	25	15	15	9	12	8.5	5	20	1
	32									
	40									
	50									
90.20.60B	63	32	21	18	11.5	16	11.5	10	25	2
	80									
	100									
	125									

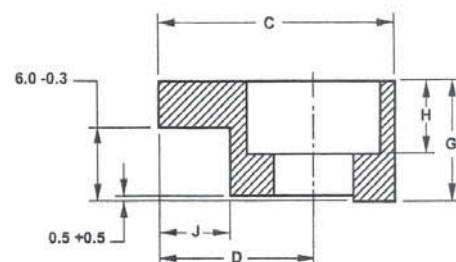
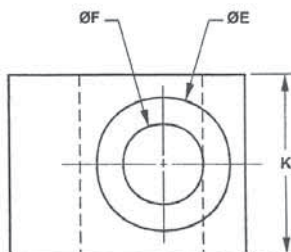

NOTE: Clamps are to be ordered with each bushing.

Automotive Demountable Self-Lubricating Bushing Clamps

CLAMP SPECIFICATIONS – CHRYSLER – STOP/BUSHING CLAMP COMBINATION BLOCK

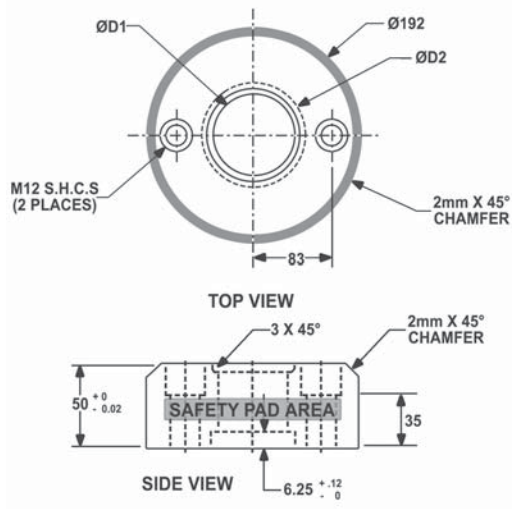

D1 mm	D2 mm	Chrysler Code	Bushing I.D.
65	73	19-010-1105	50
82	92	19-010-1106	63
102	114	19-010-1108	80
127	142	19-010-1110	100

CLAMP SPECIFICATIONS – CHRYSLER – PAD BUSHING RETAINER BLOCK

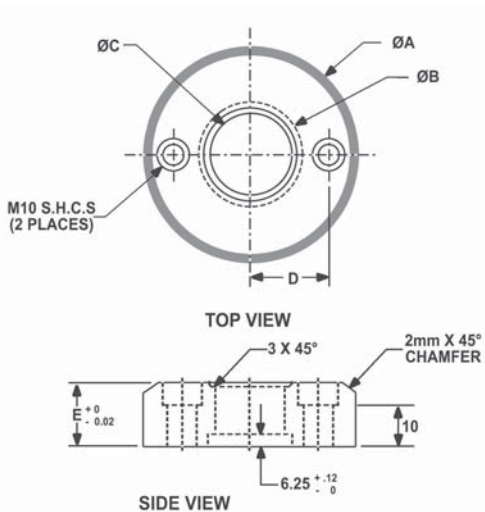

Chrysler Number	Bushing I.D.	A mm	B mm	C mm	D mm	E mm
19-010-1185	50	127	73	57	48	20
19-010-1195*						25
19-010-1186	63	140	92	70	57	20
19-010-1196*						25
19-010-1188	80	165	114	87	67	20
19-010-1198*						25

* For bottoming of pads/lower rings.

Automotive Demountable Self-Lubricating Bushing Clamps

CLAMP SPECIFICATIONS – FORD – TOE CLAMPS – 25mm

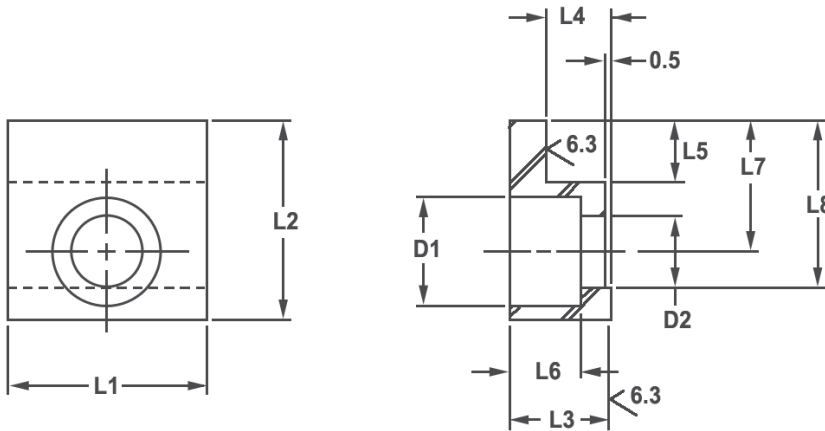

PART NUMBER MMC-0217

Ford Part Number	Bushing Size	L1 mm	L2 mm	L3 mm	L4 mm	L5 mm	L6 mm	L7 mm	L8 mm	D1 mm	D2 mm
WDX13-60-0901	25	20	20	10	6.3	5	7	12.5	16	11	7

NOTE: For FORD 25mm bushing only

CLAMP SPECIFICATIONS – FORD – TOE CLAMPS – 32mm – 100mm

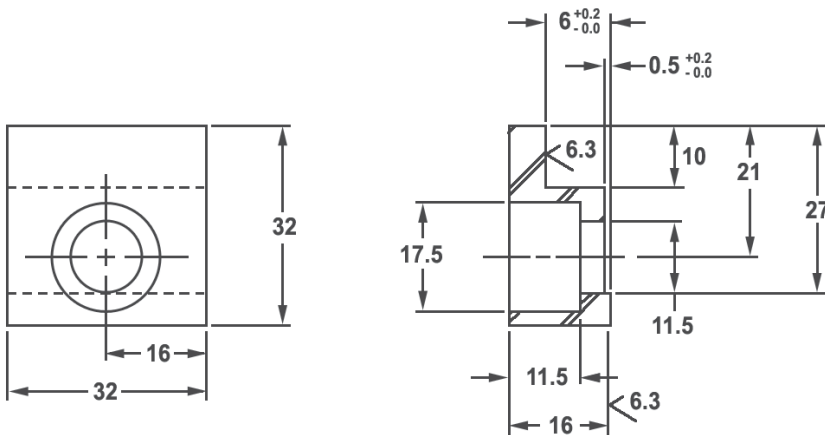

PART NUMBER MMC-0219

Ford Part Number	Bushing Size	L1 mm	L2 mm	L3 mm	L4 mm	L5 mm	L6 mm	L7 mm	L8 mm	D1 mm	D2 mm
WDX13-60-1001	63–100	32	32	16	10	10	11.5	21	27	17.5	11.5

NOTE: For FORD 63–100mm bushings only

Lifter Pins

Product Features

Lifter pins are manufactured from 1144 steel and are commonly used to handle large die sets. They conform to NAAMS standards.

The internal spring provides added assurance that the fall ring will function properly during the course of the pin's use.

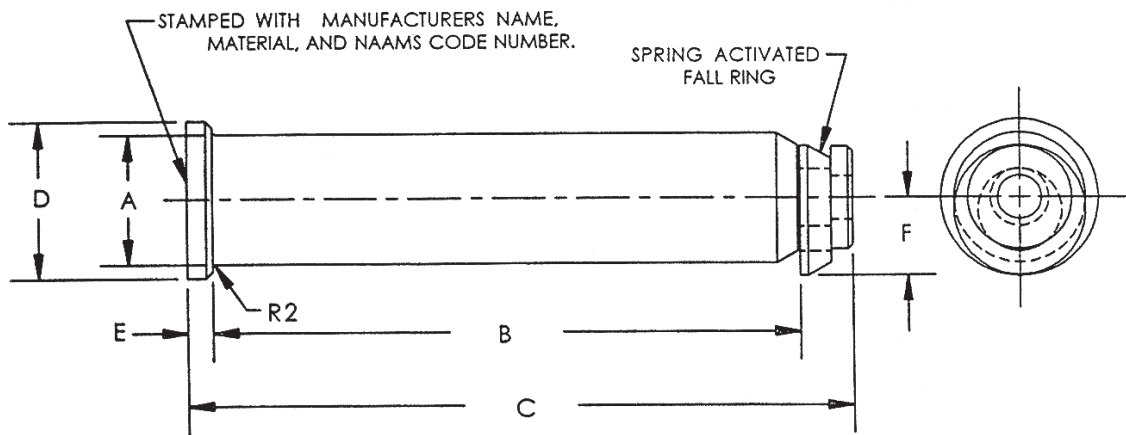

Part Number	NAAMS Code	A ⁺⁰ / _{-.03} mm	B mm	C mm	D mm	E mm	F mm	Total Die Wt. in Metric Tons (t)
LP35-125	L013512	35	125	165	45	10	21.5	0 – 2.72
LP50-190	L015019	50	190	230	63	10	31	2.72 – 9.07
LP63-280	L016328	63	280	320	76	10	37.5	9.07 – 36.28
LP80-320	L018032	80	320	370	89	15	46	36.28 – 72.57

Demountable Plain Bearing Bushings



Product Features

Demountable bushings are available in three profiles: extra long, long, and short shoulder to give optimum flexibility in die set design. The bushings are manufactured from hardened steel and are ideally suited for running with press fit or demountable posts. The bronze-plated bushings offer superior resistance to seizure, the major cause of bushing wear. They are recommended in high speed applications and where high side thrust loads are present.

Demountable bushings are tap fit into location and seat flush with the ground face of the punch holder. The bushings are held in place with toe clamps and screws which provide perfect alignment of the bushing with the bore perpendicular to the ground surface of the punch holder. The clamp and screws provide four times the holding power compared to pressed-in bushings, yet they can be easily removed and assembled thus simplifying die building and maintenance.

All bushings are equipped with figure 8 oil grooves and lubrication fittings.

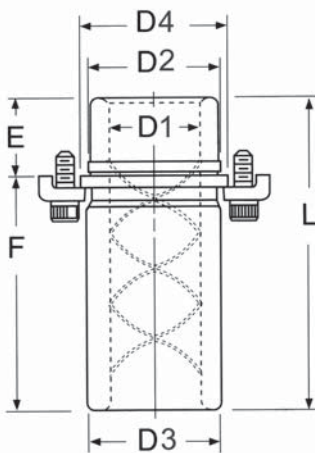

EXTRA LONG SHOULDER	D1 mm	D2 mm	D3 mm	D4 mm	E mm	F mm	L mm	Steel Part Number	Bronze Plated Part Number
	24	38	44	47	23	75	98	6-2438-65	6-2438-28
	25	38	44	47	23	75	98	6-2538-65	6-2538-28
	30	45	51	54	25	75	100	6-3045-65	6-3045-28
	32	45	51	54	25	75	100	6-3245-65	6-3245-28
	38	54	60	63	30	85	115	6-3854-65	6-3854-28
	40	54	60	63	30	85	115	6-4054-65	6-4054-28
	48	65	75	75	35	100	135	6-4865-65	6-4865-28
	50	65	75	75	35	100	135	6-5065-65	6-5065-28

NOTES:

- ◆ All demountable bushings are supplied with mounting clamps and screws. See page 32–33 for clamping dimensions or to order additional toe clamps or mounting screws.
- ◆ Bronze-plated bushings should not be pressed-in or honed.
- ◆ See pages 30–31 for die set boring specifications.

Demountable Plain Bearing Bushings

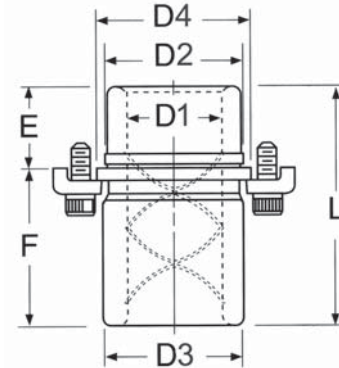

LONG SHOULDER	D1 mm	D2 mm	D3 mm	D4 mm	E mm	F mm	L mm	Steel Part Number	Bronze Plated Part Number
	18	28	28	32	18	32	50	6-1828-64	6-1828-24
	19	28	28	32	18	32	50	6-1928-64	6-1928-24
	24	38	44	47	23	47	70	6-2438-64	6-2438-24
	25	38	44	47	23	47	70	6-2538-64	6-2538-24
	30	45	51	54	25	50	75	6-3045-64	6-3045-24
	32	45	51	54	25	50	75	6-3245-64	6-3245-24
	38	54	60	63	30	50	80	6-3854-64	6-3854-24
	40	54	60	63	30	50	80	6-4054-64	6-4054-24
	48	65	73	75	35	50	85	6-4865-64	6-4865-24
	50	65	73	75	35	50	85	6-5065-64	6-5065-24
63	81	90	93	48	52	100	6-6381-64	6-6381-24	
80	100	110	115	48	52	100	6-8010-64	6-8010-24	

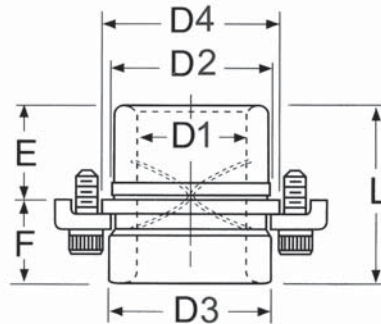

SHORT SHOULDER	D1 mm	D2 mm	D3 mm	D4 mm	E mm	F mm	L mm	Steel Part Number	Bronze Plated Part Number
	18	28	28	32	18	16	34	6-1828-63	6-1828-23
	19	28	28	32	18	16	34	6-1928-63	6-1928-23
	24	38	44	47	23	21	44	6-2438-63	6-2438-23
	25	38	44	47	23	21	44	6-2538-63	6-2538-23
	30	45	51	54	25	21	46	6-3045-63	6-3045-23
	32	45	51	54	25	21	46	6-3245-63	6-3245-23
	38	54	60	63	30	21	51	6-3854-63	6-3854-23
	40	54	60	63	30	21	51	6-4054-63	6-4054-23
	48	65	73	75	35	25	60	6-4865-63	6-4865-23
	50	65	73	75	35	25	60	6-5065-63	6-5065-23
63	81	90	93	48	27	75	6-6381-63	6-6381-23	
80	100	110	115	48	27	75	6-8010-63	6-8010-23	

Demountable Plain Bearing Low Profile Bushings



Product Features

Low profile demountable bushings are designed so that the main body of the bushing is contained within the punch holder while only a minimum of the bushing projects below the punch holder and into the die area. With minimal bushing projection, this model is ideal for dies running in presses with automatic transfer devices. Since the bushings do not need to be removed during grinding, it is well suited for applications that require often die sharpening. The bronze-plated bushings offer superior resistance to seizure, the major cause of bushing wear. They are recommended in high speed applications and where high side thrust loads are present.

Demountable bushings are tap fit into location and seat flush with the ground face of the punch holder. The bushings are held in place with toe clamps and screws which provide perfect alignment of the bushing with the bore perpendicular to the ground surface of the punch holder. The clamp and screws provide four times the holding power compared to pressed-in bushings, yet they can be easily removed and assembled, thus simplifying die building and maintenance.

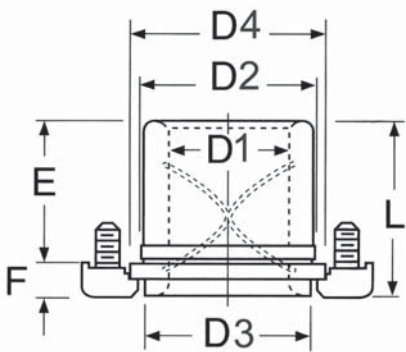

NOTES:

- ◆ All demountable bushings are supplied with mounting clamps and screws. See pages 32–33 for clamping dimensions or to order additional toe clamps or mounting screws.
- ◆ Bronze-plated bushings should not be pressed-in or honed.
- ◆ See pages 30–31 for die set boring specifications.

D1 mm	D2 mm	D3 mm	D4 mm	E mm	F mm	L mm	Steel Part Number	Bronze-Plated Part Number
18	28	28	32	18	10	28	6-1828-68	6-1828-27
19	28	28	32	18		28	6-1928-68	6-1928-27
24	38	36	47	23		33	6-2438-68	6-2438-27
25	38	36	47	23		33	6-2538-68	6-2538-27
30	45	43	54	30		40	6-3045-68	6-3045-27
32	45	43	54	30		40	6-3245-68	6-3245-27
38	54	48	63	38	14	52	6-3854-68	6-3854-27
40	54	48	63	38		52	6-4054-68	6-4054-27
48	65	64	75	48		62	6-4865-68	6-4865-27
50	65	64	75	48		62	6-5065-68	6-5065-27
63	81	79	93	61		75	6-6381-68	6-6381-27
80	100	99	115	78		92	6-8010-68	6-8010-27

Self-Lubricating Ejector Bushings

Product Features

These self-lubricating bushings contain graphite plugs which are impregnated with oil. When the bushing reach 80-90°F as a result of friction between the bushing and guide post, oil is drawn from the plug, thus lubricating the wear surface. A dark smear pattern is created on the wear surface as the oil and graphite are imbedded into the bronze or steel grain. This provides the lubrication necessary for continuous performance of the tool.



NOTES:

- ◆ See pages 30–31 for die set boring specifications.

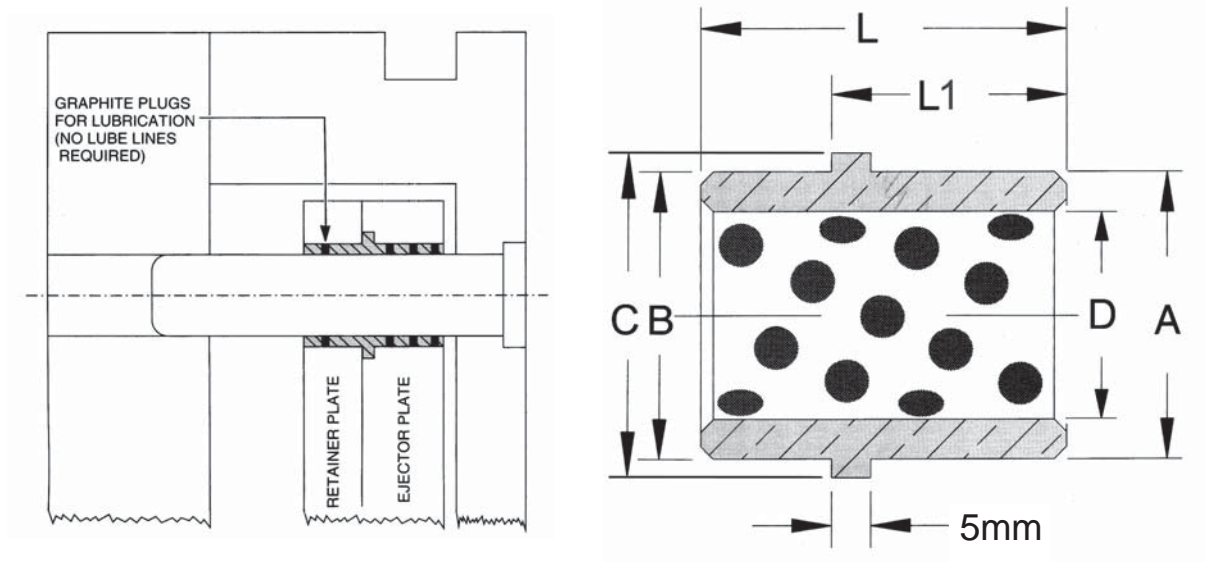

D mm	A mm	B mm	C mm	L1 mm	L mm	Part Number
20	26	26	28	25	37	MME20
25	32	32	35	29	45	MME25
30	38	38	41	29	45	MME30

Ball Bearing Cages



Product Features

Ball cages are manufactured from a heat treated aluminum alloy which provides tough, wear resistant qualities. The ball bearings are vacuum degassed quality, fatigue resistant steel and are inspected to ensure roundness, smoothness and dimensional conformance. The ball bearings are arranged in the cage in a spiral pattern to minimize tracking or grooving and assure uniform wear. Ball cages are mounted to drilled and tapped guide posts by a special washer assembly which permits the cage to rotate freely around the guide post when not under preload.

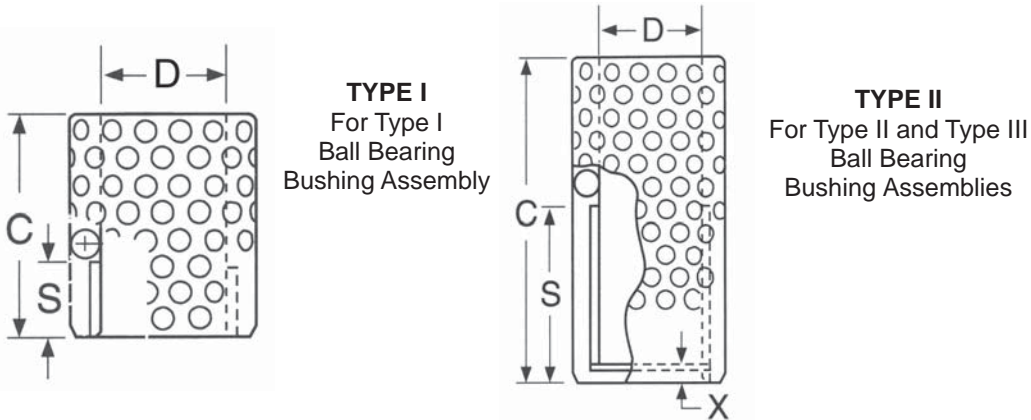

D mm	C mm	S mm	X mm	Type I Part Number	Type II Part Number
25	36	11.5	4.2	6-2503-81	—
	48	17.5		6-2504-81	—
	55	31		—	6-2505-82
	70	40		—	6-2507-82
	90	47		—	6-2509-82
	100	55		—	6-2510-82
32	110	65	4.2	—	6-2511-82
	36	11.5		6-3203-81	—
	48	17.5		6-3204-81	—
	70	40		—	6-3207-82
	90	47		—	6-3209-82
	105	55		—	6-3210-82
	115	65		—	6-3211-82
125	75	—	6-3212-82		
40	135	85	5.8	—	6-3213-82
	48	17.5		6-4004-81	—
	60	23.5		6-4006-81	—
	70	40		—	6-4007-82
	85	48		—	6-4008-82
	105	56		—	6-4010-82
	115	66		—	6-4011-82
	125	76		—	6-4012-82
	135	86		—	6-4013-82
145	96	—	6-4014-82		
155	107	—	6-4015-82		

D mm	C mm	S mm	X mm	Type I Part Number	Type II Part Number
50	70	28.5	7.0	6-5007-81	—
	84	35.5		6-5008-81	—
	105	56		—	6-5010-82
	120	65		—	6-5012-82
	140	76		—	6-5014-82
	150	86		—	6-5015-82
	160	96		—	6-5016-82
	170	108		—	6-5017-82
	185	121		—	6-5018-82
63	195	133	7.0	—	6-5019-82
	98	42.4		6-6309-81	—
	145	76		—	6-6314-82
	165	86		—	6-6316-82
	180	96		—	6-6318-82
	190	107		—	6-6319-82
	205	121		—	6-6320-82
80	215	132	8.5	—	6-6321-82
	98	42.5		6-8009-81	—
	145	76		—	6-8014-82
	165	86		—	6-8016-82
	180	96		—	6-8018-82
	190	107		—	6-8019-82
	205	121		—	6-8020-82
	215	132		—	6-8021-82

Ball Bearing Demountable Bushings

Product Features

Demountable bushings are tap fit into location and seat flush with the ground face of the punch holder. The bushings are held in place with toe clamps and screws which provide perfect alignment of the bushing with the bore perpendicular to the ground surface of the punch holder. The clamp and screws provide four times the holding power compared to pressed-in bushings, yet they can be easily removed and assembled thus simplifying die building and maintenance.



D mm	D1 mm	D2 mm	D3 mm	D4 mm	E mm	F mm	L1 mm	Part Number
25	33	45	50.80	55	30	35	65	6-2503-85
						50	80	6-2505-85
						65	95	6-2506-85
32	40	54	55.88	64	30	50	80	6-3205-85
						65	95	6-3206-85
						80	110	6-3208-85
40	48	65	73.03	77	30	50	80	6-4005-85
						65	95	6-4006-85
						80	110	6-4008-85
						100	130	6-4010-85
50	62	81	85.73	95	50	60	110	6-5006-85
						80	130	6-5008-85
						100	150	6-5010-85
						120	170	6-5012-85
63	75	95	101.85	109	50	100	150	6-6310-85
						120	170	6-6312-85
						140	190	6-6314-85
80	92	108	114.30	125	61	117	178	6-8011-85

NOTES:

- ◆ All demountable bushings are supplied with mounting clamps and screws. See pages 32–33 for clamping dimensions or to order additional toe clamps or mounting screws.
- ◆ See pages 30–31 for die set boring specifications.

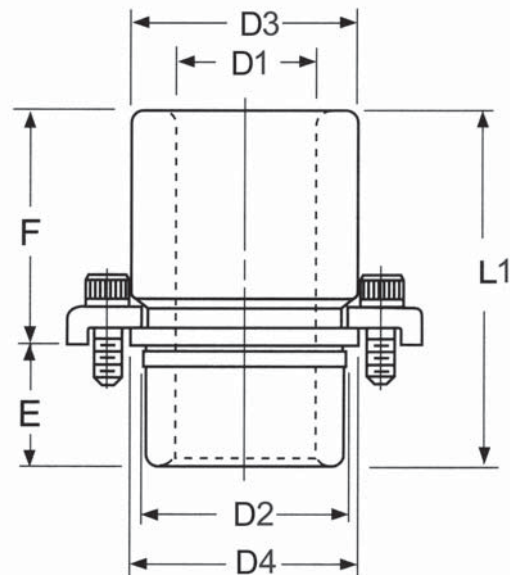

Ball Bearing Straight Sleeve Bushings



Product Features

Press fit bushings are manufactured from high quality hardened steel, the bushings are finish ground for a press fit. Like all ball bearing components, these straight sleeve bushings are completely interchangeable.

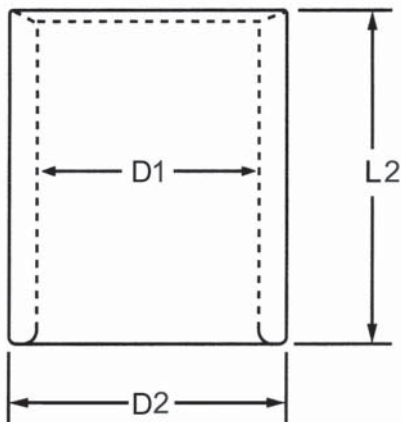

INSTALLATION INSTRUCTIONS

In order to avoid the bushing close-in which occurs as a result of press-fit, these bushings should be retained with a Bushing Mount. When so installed, it is not necessary to hone the bushing bore after installation, and the bushing fit will be correct.

APPLICATION OF THE BUSHING MOUNT

1. Degrease bushing OD and die shoe bore with alcohol, acetone or other volatile solvent and wipe dry.
2. Apply Bushing Mount sparingly and wring bushing into die shoe.
3. Allow a 4-hour cure at 72° F (23° C). Do not disturb bushing until cure is complete.

Bushing Mount Part number: 9-60-82

Post Diameter mm	D1 mm	D2 mm	L2 mm	Part Number
25	33	45	65	6-2506-86
			80	6-2508-86
			95	6-2509-86
			110	6-2511-86
			130	6-2513-86
32	40	54	80	6-3208-86
			95	6-3209-86
			110	6-3211-86
			130	6-3213-86
			150	6-3215-86
40	48	65	170	6-3217-86
			80	6-4008-86
			95	6-4009-86
			110	6-4011-86
			130	6-4013-86
			150	6-4015-86
			170	6-4017-86
			190	6-4019-86
			215	6-4021-86

Post Diameter mm	D1 mm	D2 mm	L2 mm	Part Number
50	62	81	110	6-5011-86
			130	6-5013-86
			150	6-5015-86
			170	6-5017-86
			190	6-5019-86
			215	6-5021-86
			240	6-5024-86
			265	6-5026-86
			150	6-6315-86
			170	6-6317-86
63	75	95	190	6-6319-86
			215	6-6321-86
			240	6-6324-86
			265	6-6326-86
80	92	112	150	6-8015-86
			170	6-8017-86
			190	6-8019-86
			215	6-8021-86
			240	6-8024-86
			265	6-8026-86

Demountable Ball Bearing Stripper Bushings and Cages

Product Features

Type III cages are made using the same material and control standards as our Type I & II cages. Type III cages use an external snap ring to act as a cage carrier and stop. This allows the cage to rotate freely around the guide post when not under preload and prevents the cage from pushing through the guide bushing at full stroke. Ball bearings are arranged in a spiral pattern in the cage to minimize tracking or grooving and assure uniform wear.

Low profile demountable bushings give maximum flexibility in die set design. The low profile bushing, coupled with low mount clamping, provide maximum available die set use. The bushings are manufactured from hardened steel and are designed for use with Type III cage components. These demountable bushings are a tap fit into location and seat flush with the ground face of the die holder. The bushings are held in place with low mount clamps and screws which provide perfect alignment of the bushing with the bore perpendicular to the ground surface of the die holder.



Cage Data

D mm	L mm	G mm	D2 mm	Part Number
25	40	1.6	30.3	6-2504-83
	52	1.6	30.3	6-2505-83
32	40	1.9	36	6-3204-83
	52	1.9	36	6-3205-83
40	52	1.9	45.5	6-4005-83
	64	1.9	45.5	6-4006-83
50	74	2.2	57	6-5007-83
	88	2.2	57	6-5008-83

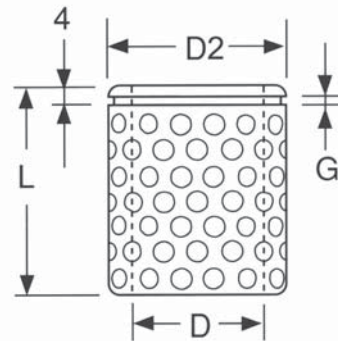

Bushing Data

Post Diameter mm	D1 mm	D2 mm	D4 mm	E mm	F mm	L mm	Part Number
25	33	45	51	20	10	30	6-2520-87
				25	10	35	6-2525-87
32	40	54	60	20	10	30	6-3220-87
				25	10	35	6-3225-87
				32	10	42	6-3232-87
40	48	65	75	29	10	39	6-4029-87
				36	10	46	6-4036-87
				44	10	54	6-4044-87
50	62	81	91	36	10	46	6-5036-87
				44	10	54	6-5044-87

NOTES:

- ◆ All demountable bushings are supplied with mounting clamps and screws. See pages 32–33 for clamping dimensions or to order additional toe clamps or mounting screws.
- ◆ See pages 30–31 for die set boring specifications.

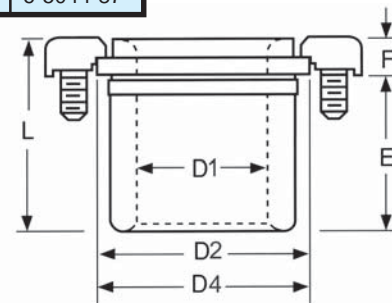

Mounting Accessories

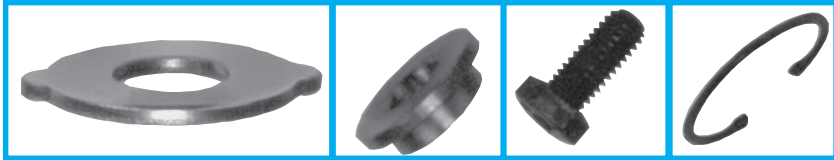

BALL CAGE WASHER ASSEMBLY

Nominal Post Diameter A mm	Washer Assembly Part Number		Stop Washer-Retainer		Bushing Stop Washer	Hex Head Screw	Snap Ring-Ball Bearing Cages
	Type I Assembly	Type II Assembly	Type I	Type II and III	Type II and III	Type I, II and III	Type II and III
25	6-0025-81	6-0025-82	6-2500-85	6-2500-83	6-2500-84	6-0620-933 M6 x 20 DIN933 8G or 10K	6-2500-86
32	6-0032-81	6-0032-82	6-3200-85	6-3200-83			6-3200-86
40	6-0040-81	6-0040-82	6-4000-85	6-4000-83	6-4000-84	6-1025-933 M10 x 25 DIN933 8G or 10K	6-4000-86
50	6-0050-81	6-0050-82	6-5000-85	6-5000-83			6-5000-86
63	6-0063-81	6-0063-82	6-6300-85	6-6300-83			6-6300-86
80	6-0080-81	6-0080-82	6-8000-85	6-8000-83			6-8000-86

NOTES:

- ◆ **TYPE I** Assembly includes stopwasher retainer and head hex screw.
- ◆ **TYPE II** Assembly includes stopwasher retainer, bushing stopwasher, hex head screw and snap ring.

BUSHING MOUNT

Part Number	Volume
9-60-82	118 mL

NOTES:

- ◆ A bushing mount is used when installing straight sleeve ball bearing bushings to avoid bushing close-in as a result of press-fit.

BALL CAGE WASHER ASSEMBLY

Guide Post Tap Sizes		Required Seating Torque	
Diameter O mm	Tap Size	Newtons per mm	Lbs per Inch
25 – 32	M6	56	320
40 – 50	M10	98	560
63 – 80	M10	236	1350

BALL BEARING BUSHING LUBRICATION RECOMMENDATION

During the operation of the Ball Bearing Bushing Assembly, add lubricant once each 8-hour shift by spray or brush application. Use a refined mineral oil of viscosity 290/340 SSU @ 100° F (38° C) containing “EP” additives and rust inhibitors.

Ball Bearing Components Selection Guide

Product Features

For proper post, bushing and cage selection, the operating conditions of the die must be taken into consideration. Factors such as press speed, shut height, stroke length and operating environment all play a role in selecting the appropriate operating condition to give the best performance possible of your components. The operating conditions include full preload, relieved and total disengagement.

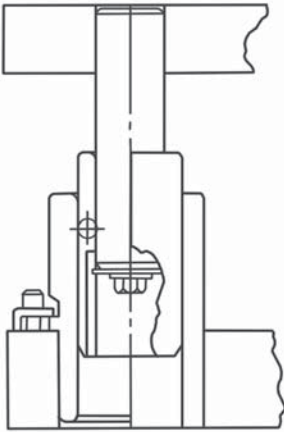

Type I
Full Pre-Load
Throughout Stroke

Type I component assemblies ensure that all ball bearings remain in constant contact with the guide post and bushing throughout the entire press stroke. This assembly is recommended for higher speed, short stroke dies.

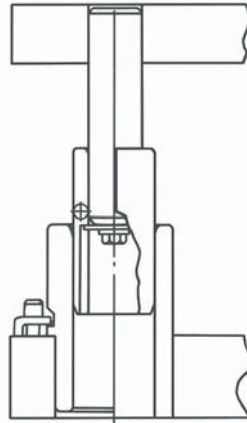

Type II
Pre-Load Relieved
or Partially Relieved

Type II component assemblies are designed so the ball cage never leaves the bushing; however the guide post disengages the bushing at the beginning of each stroke. This assembly is often preferred as pinch points are eliminated and foreign matter cannot get inside the assembly and damage the components. This assembly is often utilized in medium and long stroke dies.

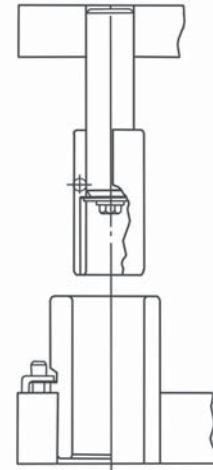

Type III
Total Disengagement
of Cage from Bushing

Type III component assemblies are designed so the ball cage totally disengages from the bushing. This assembly is utilized on long stroke applications.

NOTES:

- ◆ See ball bearing lubrication recommendation on page 22.

Type I Component Selection Guide

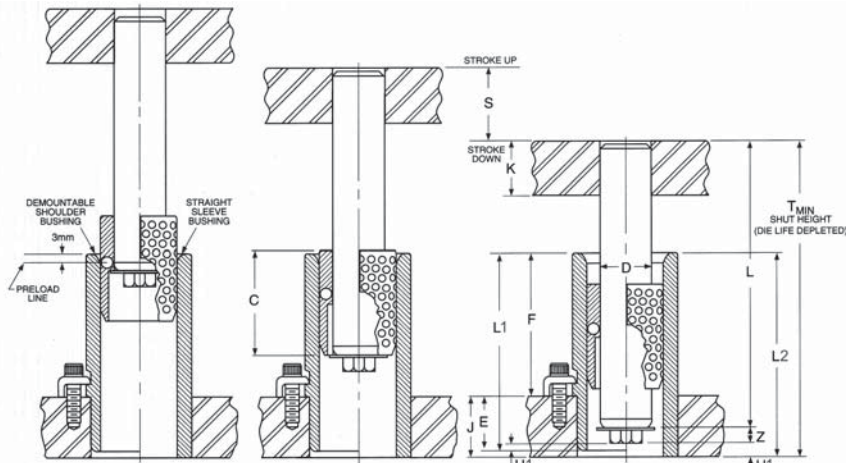

Post Diam. D mm	Z mm	E mm	U1 mm
25	7	30	3
32	7	30	
40	9.5	30	
50	9.5	50	
63	9.5	50	
80	9.5	50	

PRESS FIT POSTS

- Calculate L, the desired guide post length, using one of the following 2 formulas:
 Assembly with Straight Sleeve Bushings: $L = T - U_1 - Z$
 Assembly with Demountable Bushings: $L = T - U_1 - Z - J + E$
- Select a post length from the catalog that is equal to L calculated above. If the calculated L value is not a standard catalog length, you have two options. Choose the next longest length and cut off to the calculated L dimension or select a shorter length and recess the post in the punch holder to obtain correct L dimension.
Note: Press fit length should be equal to or greater than the diameter of the guide post.

DEMOUNTABLE POSTS

- Calculate F_1 , the desired guide post length, using one of the following 2 formulas:
 Assembly with Straight Sleeve Bushings: $F_1 = T - U_1 - Z - K$ (Note $F + J + K + Y < T$)
 Assembly with Demountable Bushing: $F_1 = T - U_1 - Z - J + E - K$ (Note $L_2 + K + Y < T$)
- Select a post length from the catalog that is equal to F_1 calculated above. If the calculated F_1 value is not a standard catalog length, choose a catalog length that is close to but less than the calculated F_1 .
Note: Demountable posts cannot be cut off. See page 4 for standard post lengths (F_1).

BUSHING & CAGE SELECTION

Selection of a Type 1 Ball bearing bushing and cage assembly is based on the required stroke and the guide post diameter.

- Determine the guide post diameter required and the stroke required.
- Using the selection chart on page 25, find the desired stroke. Move down this column to the colored square on the horizontal line opposite the required post diameter.
- Select the required bushing length which is listed to the left of the selected square in the columns labeled demountable shoulder and straight sleeve.

Note: For applications with no off-center loading, select the bushing with the shortest overall length from the selection chart. However for longer stroke applications or where side-loading may be present select the bushing with the longest possible length to provide optimal guidance.

- Select the required cage length which is also listed to the left of the selected square in the column labeled "Ball Cage."

Note: Shut height permitting, select the longest cage length possible for optimal performance.

NOTES:

- ◆ If die grind is not required, stroke may be increased by the amount of die grind allowance, dimension X, found in the right most column of the selection chart.
- ◆ A die set designed for a particular stroke may be used in any press of lesser stroke but never in any press where the stroke is greater than originally chosen.
- ◆ Die shoe thickness must be greater than "E" dimension when shoulder bushings are selected.

Type I Component Selection Guide

NOM. POST DIA.	BALL BUSHING			BALL CAGE	STROKE "S" INCLUDING DIE GRIND ALLOWANCE											*MAXIMUM DIE WEAR ALLOWANCE		
	SHOULDER	SLEEVE			D mm	F mm	L ₁ mm	L ₂ mm	C mm	20	40	60	80	100	120		140	160
25	35	65	65	36												48		
	50	80	80															
	65	95	95															
	–	–	110															
	–	–	130															
32	50	80	80	36	48	48	48	48	48	48	48	48	48	48	48	48	48	10
	65	95	95															
	80	110	110															
	–	–	130															
	–	–	150															
40	50	80	80	48	60	60	60	60	60	60	60	60	60	60	60	60	60	10
	65	95	95															
	80	110	110															
	100	130	130															
	–	–	150															
50	60	110	110	70	84	84	84	84	84	84	84	84	84	84	84	84	84	10
	80	130	130															
	100	150	150															
	120	170	170															
	–	–	190															
63	100	150	150	98	98	98	98	98	98	98	98	98	98	98	98	98	98	15
	120	170	170															
	140	190	190															
	–	–	215															
	–	–	240															
80	–	–	150	98	98	98	98	98	98	98	98	98	98	98	98	98	98	15
	–	–	170															
	–	–	190															
	–	–	215															
	–	–	240															

If your selection falls in a white square, use Type II or Type III.

Type II & III Component Selection Guide

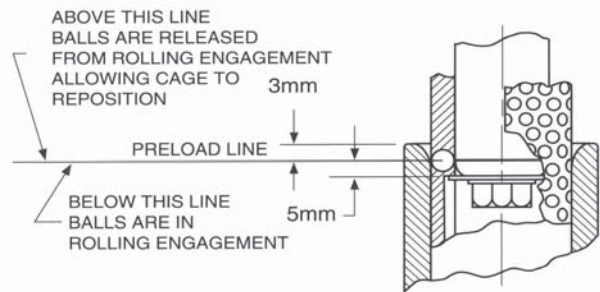
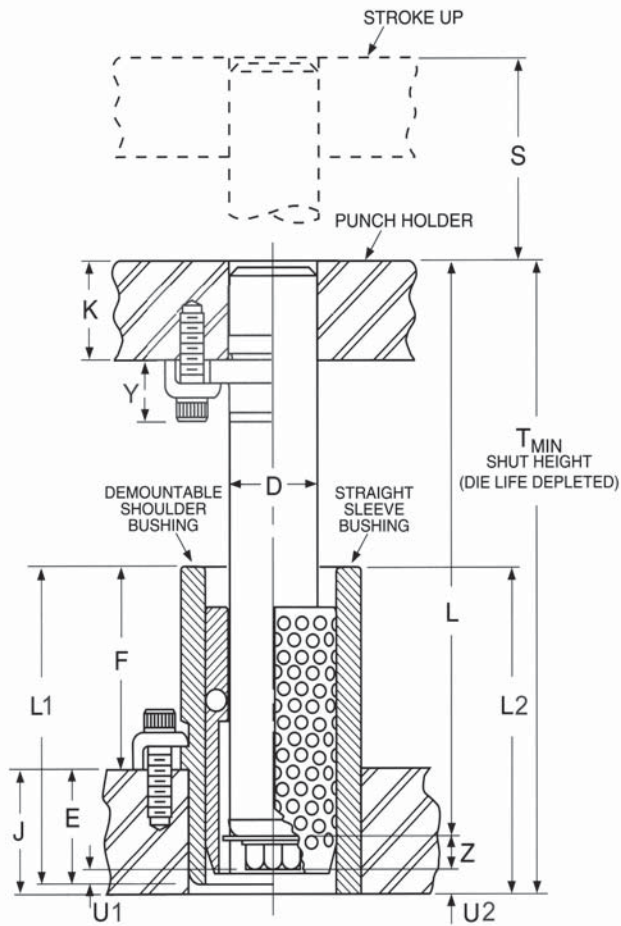

D mm	Z mm	E mm	U1 mm	U2 mm	Y mm
25	10.5	30	1.5	3.5	14.7
32	10.5	30		3.5	18.9
40	13	30		4	18.9
50	13	50		4	18.9
63	13	50		4	18.9
80	13	50		4	18.9

Type II & III Component Selection Guide

PRESS FIT POSTS

1. Calculate L, the desired guide post length, using one of the following 2 formulas:
Assembly with Straight Sleeve Bushings: $L=T-U_2-Z$
Assembly with Demountable Bushings: $L=T-U_2-Z-J+E$
2. Select a post length from the catalog that is equal to L calculated above. If the calculated L value is not a standard catalog length, you have two options. Choose the next longest length and cut off to the calculated L dimension or select a shorter length and recess the post in the punch holder to obtain correct L dimension.

Note: Press fit length should be equal to or greater than the diameter of the guide post.

DEMOUNTABLE POSTS

1. Calculate F_1 , the desired guide post length, using one of the following 2 formulas:
Assembly with Straight Sleeve Bushings: $F_1=T-U_2-Z-K$ (Note $F+J+K+Y<T$)
Assembly with Demountable Bushings: $F_1=T-U_1-Z-J+E-K$ (Note $L_2+K+Y<T$)
2. Select a post length from the catalog that is equal to F_1 calculated above. If the calculated F_1 value is not a standard catalog length, choose a catalog length that is close to but less than the calculated F_1 .

Note: Demountable posts cannot be cut off. See page 4 for standard post lengths (F_1).

BUSHING & CAGE SELECTION

Selection of a Type II and Type III Ball bearing bushing and cage assembly is based on the required stroke and the guide post diameter.

1. Determine the guide post diameter required and the stroke required.
2. Determine the desired operating condition or the extent to which the cage leaves the bushing.
3. Determine if a demountable or straight sleeve bushing is to be used.
4. Using the selection chart on pages 28 & 29, find the desired stroke (S). Move down this column to the colored square on the horizontal line opposite the required post diameter. Find the colored square in the desired operating condition.
5. Select the required bushing length which is listed to the left of the selected square in the columns labeled demountable shoulder or straight sleeve.

Note: For applications with no off-center loading, select the bushing with the shortest overall length from the selection chart. However for longer stroke applications or where side-loading may be present select the bushing with the longest possible length to provide optimal guidance.

6. Select the required cage length which is also listed to the left of the selected square in the column labeled "Ball Cage."

Note: Shut height permitting, select the longest cage length possible for optimal performance.

NOTES:

- ◆ If stroking rate is under 150 rpm, Figure B (on page 28) is recommended, which allows the ball cage to reposition at each stroke.

- ◆ A die set designed for a particular stroke may be used in any press of lesser stroke but never in any press where the stroke is greater than originally chosen.
- ◆ Die shoe thickness must be greater than "E" dimension when shoulder bushings are selected.

Type II & III

Bushing & Ball Cage Selection Guide

CAUTION

Be sure bushing does not strike punch holder at minimum shut height. If this condition exists, use shorter bushing and corresponding ball cage.

■ Type II and III components provide Type I operating conditions

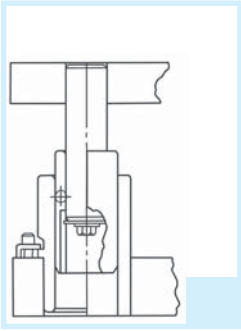

Figure A
Partial Preload

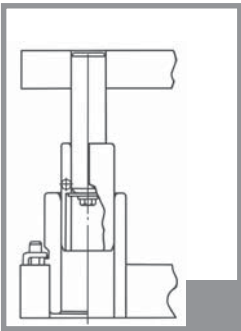

Figure B
Preload Relieved

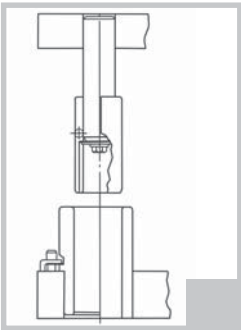

Figure C
Unlimited stroke cage leaves bushing

NOTES:

- ◆ Sleeve Bushing: $L_2 + K$ must be less than T
- ◆ Shoulder Bushing: $J + F + K$ must be less than T
- ◆ Demountable Bushing: Maximum $F = T - J - K$
- ◆ Sleeve Bushing: Maximum $L_2 = T - K$

Nominal Post Diameter D mm	Ball Bushing			Ball Cage	
	F mm	L1 mm	L2 mm	C mm	
25	35	65	65	55	
	50	80	80	70	
	65	95	95	90	
	–	–	110	100	
	–	–	130	110	
32	50	80	80	70	
	65	95	95	90	
	80	110	110	105	
	–	–	130	115	
	–	–	150	125	
	–	–	170	135	
40	50	80	80	70	
	65	95	95	85	
	80	110	110	105	
	100	130	130	115	
	–	–	150	125	
	–	–	170	135	
	–	–	190	145	
	–	–	215	155	
50	60	110	110	105	
	80	130	130	120	
	100	150	150	140	
	120	170	170	150	
	–	–	190	160	
	–	–	215	170	
	–	–	240	185	
	–	–	265	195	
63	100	150	150	145	
	120	170	170	165	
	140	190	190	180	
	–	–	215	190	
	–	–	240	205	
	–	–	265	215	
80	–	–	150	145	
	–	–	170	165	
	–	–	190	180	
	–	–	215	190	
	–	–	240	205	
	–	–	265	215	

Bore Size Data for Bushings

BORE SIZES FOR DEMOUNTABLE PLAIN BEARING BUSHINGS

Bushing Diameter mm	Bushing Locating Diameter M6		Punch Holder Bore H6		Assembly Fit	
	mm	mm	mm	mm	mm	
18 - 19	28	+0.021	28	+0.013	0.005	LOOSE
		+0.008		-0.000	0.021	TIGHT
24 - 25	38	+0.025	38	+0.016	0.007	LOOSE
		+0.009		-0.000	0.025	TIGHT
30 - 32	45	+0.025	45	+0.016	0.007	LOOSE
		+0.009		-0.000	0.025	TIGHT
38 - 40	54	+0.030	54	+0.019	0.008	LOOSE
		+0.011		-0.000	0.030	TIGHT
48 - 50	65	+0.030	65	+0.019	0.008	LOOSE
		+0.011		-0.000	0.030	TIGHT
63	81	+0.035	81	+0.022	0.009	LOOSE
		+0.013		-0.000	0.035	TIGHT
80	100	+0.035	100	+0.022	0.009	LOOSE
		+0.013		-0.000	0.035	TIGHT

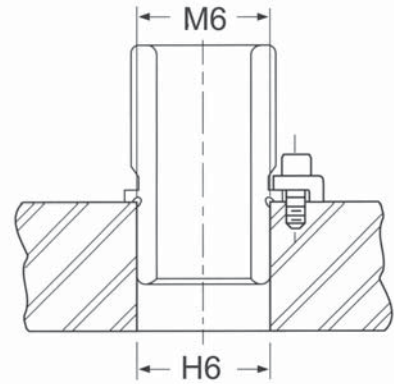

BORE SIZES FOR STRAIGHT SLEEVE BALL BEARING BUSHINGS

Post Diameter mm	Bushing Diameter D2		Die Shoe Bore H6		Assembly Fit	
	mm	mm	mm	mm	mm	
25	45	-0.017	45	+0.016	0.017	LOOSE
		-0.024		-0.000	0.040	
32	54	-0.020	54	+0.019	0.020	LOOSE
		-0.028		-0.000	0.047	
40	65	-0.020	65	+0.019	0.020	LOOSE
		-0.028		-0.000	0.047	
50	81	-0.024	81	+0.022	0.024	LOOSE
		-0.034		-0.000	0.056	
63	95	-0.024	95	+0.022	0.024	LOOSE
		-0.034		-0.000	0.056	
80	112	-0.024	112	+0.022	0.024	LOOSE
		-0.034		-0.000	0.056	

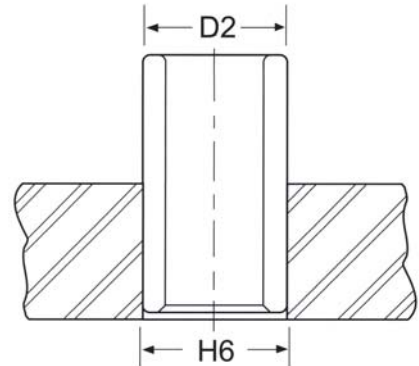

BORE SIZES FOR DEMOUNTABLE BALL BEARING BUSHINGS

Bushing Diameter mm	Bushing Locating Diameter M5		Punch Holder Bore H6		Assembly Fit	
	mm	mm	mm	mm	mm	
25	45	+0.020	45	+0.016	0.007	LOOSE
		+0.009		-0.000	0.020	TIGHT
32	54	+0.024	54	+0.019	0.008	LOOSE
		+0.011		-0.000	0.024	TIGHT
40	65	+0.024	65	+0.019	0.008	LOOSE
		+0.011		-0.000	0.024	TIGHT
50	81	+0.028	81	+0.022	0.009	LOOSE
		+0.013		-0.000	0.028	TIGHT
63	95	+0.028	95	+0.022	0.009	LOOSE
		+0.013		-0.000	0.028	TIGHT
80	108	+0.032	108	+0.025	0.010	LOOSE
		+0.015		-0.000	0.032	TIGHT

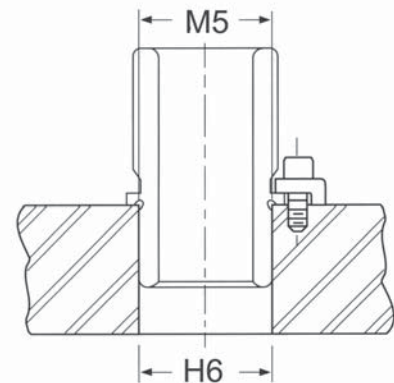

Bore Size Data for Guide Posts

BORE SIZES FOR DEMOUNTABLE GUIDE POSTS

Guide Post Diameter		Bore Diameter S6	Assembly Fit	
18	-0.016	-0.025	0.002	LOOSE
	-0.027	-0.036	0.020	TIGHT
19	-0.020	-0.031	0.002	LOOSE
	-0.033	-0.044	0.024	TIGHT
24	-0.020	-0.031	0.002	LOOSE
	-0.033	-0.044	0.024	TIGHT
25	-0.020	-0.031	0.002	LOOSE
	-0.033	-0.044	0.024	TIGHT
30	-0.020	-0.031	0.002	LOOSE
	-0.033	-0.044	0.024	TIGHT
32	-0.025	-0.038	0.003	LOOSE
	-0.041	-0.054	0.029	TIGHT
38	-0.025	-0.038	0.003	LOOSE
	-0.041	-0.054	0.029	TIGHT
40	-0.025	-0.038	0.003	LOOSE
	-0.041	-0.054	0.029	TIGHT
48	-0.025	-0.038	0.003	LOOSE
	-0.041	-0.054	0.029	TIGHT
50	-0.025	-0.038	0.003	LOOSE
	-0.041	-0.054	0.029	TIGHT
63	-0.030	-0.047	0.002	LOOSE
	-0.049	-0.066	0.036	TIGHT
80	-0.030	-0.053	0.004	TIGHT
	-0.049	-0.072	0.042	TIGHT

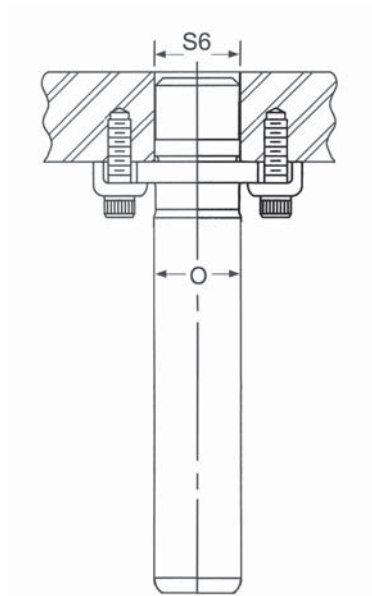

BORE SIZES FOR PRESS FIT GUIDE POSTS

Guide Post Diameter	Bore Diameter S6
18	-0.025
	-0.036
19	-0.031
	-0.044
24	-0.031
	-0.044
25	-0.031
	-0.044
30	-0.031
	-0.044
32	-0.038
	-0.054
38	-0.038
	-0.054
40	-0.038
	-0.054
48	-0.038
	-0.054
50	-0.038
	-0.054
63	-0.047
	-0.066
80	-0.053
	-0.072

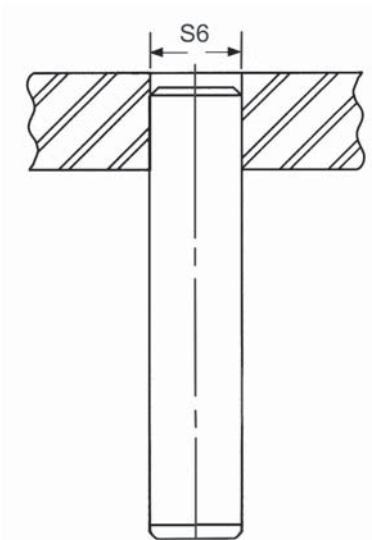

Clamping Specifications

DEMOUNTABLE SHOULDER BUSHING CLAMP ARRANGEMENT SELECTION DATA			
NOM. POST DIA.	A (L-R FEED)	B (F-B FEED) (CENTER POST SETS)	C (ROUND DIES)
25 & 32			
40			
50			
63			

NOTE: If not specified, clamp arrangement A will be furnished. Clamp arrangement B is furnished on Center Post Sets.

CLAMP ARRANGEMENTS & DIMENSIONS FOR BUSHINGS & GUIDE POSTS

Clamp	Screw	A mm	B mm	C mm	D mm
6-90-1	M6	14.3	15.9	4.9	8.7
6-91-1	M8	19.8	15.9	4.9	9.5
6-93-1	M8	19.6	15.9	6.3	10.9
6-95-1	M6	12.3	12.7	3.2	5.6
6-96-1	M6	17.5	14.5	5	10
6-97-1	M8	24.6	18.9	7.9	13

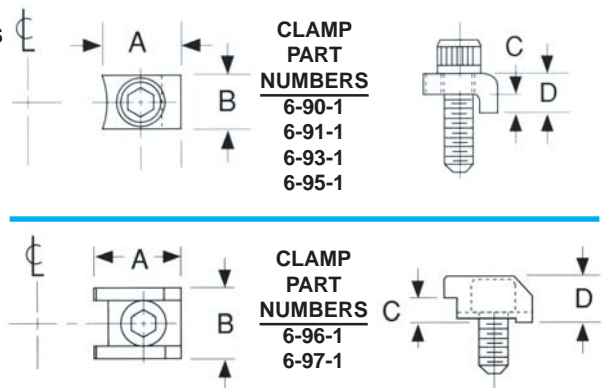

RETAINER PLUG DIMENSIONAL DATA

Part Number	D2 mm	D3 mm	A mm	B mm	D4 mm	L4 mm	H3 mm
5-1800-88	18	25	3.3	4.0	26	3.5	25
5-2400-88	24	32	5.0	4.2	33	5.5	30
5-3000-88	30	40	5.0	7.0	41	5.5	40
5-3800-88	38	50	5.0	10.0	51	5.5	51
5-4800-88	48	63	5.0	13.0	64	5.5	59
5-6300-88	63	76	5.0	19.0	77	5.5	70
5-8000-88	80	93	5.0	25.0	95	5.5	87

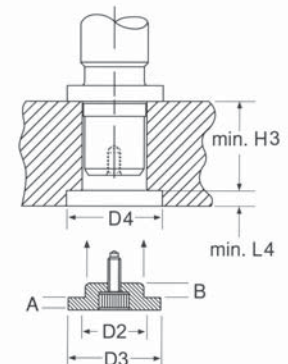

NOTES:

- ◆ All tapped holes for retainer plugs are tapped to two (2) times the diameter of the screw.

We offer two ways of mounting the pins into the die plate: clamps or a retainer plug.

Clamping Specifications

CLAMP ARRANGEMENTS FOR DEMOUNTABLE BUSHINGS

Post Diam mm	Clamp Part #	Screw Part #	Screw Desc.	Clamps & Screws per Bushing	M mm	N mm
18 & 19	6-95-1	9-06020-91	M6	2	19.5	25.5
24 & 25	6-90-1	9-06020-91	M6	2	27.5	35
30 & 32	6-91-1	9-08020-91	M8 x 20	3	32.5	42.5
38 & 40	6-91-1	9-08020-91	M8 x 20	3	37	47
48 & 50	6-91-1	9-08020-91	M8 x 20	4	44.5	54.5
63	6-91-1	9-08020-91	M8 x 20	4	52	62
80	6-91-1	9-08020-91	M8 x 20	4	62	72

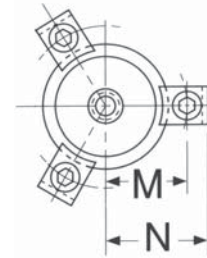

**Bushing
3 Clamp
Arrangement**

CLAMP ARRANGEMENTS FOR LOW PROFILE DEMOUNTABLE BUSHINGS

Post Diam mm	Clamp Part #	Screw Part #	Screw Desc.	Clamps & Screws per Bushing	M mm	N mm
18 & 19	6-95-1	9-06020-91	M6	2	19.5	25.5
24 & 25	6-96-1	9-06020-91	M6	3	30	37.1
30 & 32	6-96-1	9-06020-91	M6	3	34	41.1
38 & 40	6-97-1	9-08020-91	M8 x 20	4	41	52.1
48 & 50	6-97-1	9-08020-91	M8 x 20	4	47	58.1
63	6-97-1	9-08020-91	M8 x 20	4	56	67.1
80	6-97-1	9-08020-91	M8 x 20	4	67	78.1

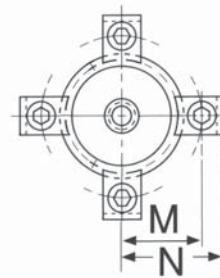

**Bushing
2 & 4 Clamp
Arrangement**

CLAMP ARRANGEMENTS FOR DEMOUNTABLE GUIDE POSTS

Post Diam mm	Clamp Part #	Screw Part #	Screw Desc.	Clamps & Screws per Post	M mm	N mm	P mm
18 & 19	6-95-1	9-06020-91	M6	3	16.0	22.0	16.5
24 & 25	6-90-1	9-06020-91	M6	3	20.3	27.8	20.8
30 & 32	6-93-1	9-08020-91	M8 x 20	3	25.5	35.5	24.6
38 & 40	6-93-1	9-08020-91	M8 x 20	4	30.0	40.0	26.9
48 & 50	6-93-1	9-08020-91	M8 x 20	4	36.5	46.5	38.5
63	6-93-1	9-08020-91	M8 x 20	4	42.5	52.5	42.7
80	6-93-1	9-08020-91	M8 x 20	4	51.0	61.0	48.8

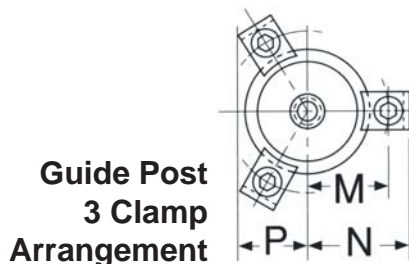

**Guide Post
3 Clamp
Arrangement**

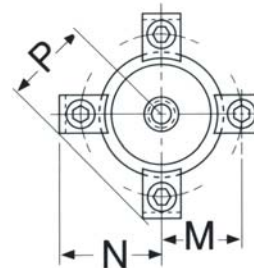

**Guide Post
4 Clamp
Arrangement**



PINS & BUSHINGS - METRIC



Distributed by:

www.danly.com
info@anchordanly.com

WITHIN THE USA & CANADA

CALL: 800-652-6426

FAX: 800-406-4410

OUTSIDE THE USA & CANADA

CALL: 248-489-7816

FAX: 248-553-6842

